



MODEL NO.

USER INSTRUCTIONS

MSA ANCHORAGE CONNECTOR STRAP



WARNING

*National standards and state, provincial and federal laws require the user to be trained before using this product. Use this manual as part of a user safety training program that is appropriate for the user's occupation. These instructions must be provided to users before use of the product and retained for ready reference by the user. The user must read, understand (or have explained), and heed all instructions, labels, markings and warnings supplied with this product and with those products intended for use in association with it. **FAILURE TO DO SO MAY RESULT IN SERIOUS INJURY OR DEATH.***

1.0 MODELS AND SPECIFICATIONS

TABLE 1. ANCHORAGE CONNECTOR STRAP MODELS COVERED BY THESE INSTRUCTIONS

MODEL NUMBER	MATERIAL	MINIMUM BREAKING STRENGTH		LENGTH		APPROXIMATE WEIGHT	
		LBF	KN	FT	M	LBS	KG
505282	Nylon	5,000	22.2	5.0	1.5	1.3	0.6
505298	Polyester	5,000	22.2	5.0	1.5	1.6	0.7
10023490	Nylon	5,000	22.2	5.0	1.5	1.8	0.8
10023487	Aramid Fiber	5,000	22.2	5.0	1.5	1.7	0.8

1.1 SPECIFICATIONS - MSA ANCHORAGE CONNECTOR STRAP

- MSA Anchorage Connector Straps identified in Table 1 meet ANSI Z359.1 and ANSI A10.14 standards and applicable OSHA regulations.
- The Anchorage Connector Strap is capable of withstanding a load of 5,000 lbf (22.2 kN) without breaking or permanent deformation.
- The Anchorage Connector Strap is designed for the attachment of a single personal fall arrest system.



For More Information: Call (1-800-MSA-2222) or Visit Our Website at (www.MSAnet.com)



Be Sure.
Choose MSA.

MINE SAFETY APPLIANCES COMPANY
PITTSBURGH, PENNSYLVANIA, U.S.A. 15230

- The Anchorage Connector Strap webbing is 3 in (76 mm) nominal width with a minimum breaking strength, when new, of 21,000 lbf (93.2 kN).
- The Thermatek™ Anchorage Connector Strap (Model 10023487) webbing is 3 in. (76mm) nominal width with a minimum breaking strength of 10,000 lbf (44.4 kN)
- Webbing is color dyed for identification. Nylon Anchorage Connector Straps are yellow, polyester Anchorage Connector Straps are orange, and Thermatek Anchorage Connector Straps are black.
- Hardware (D-ring) is forged steel, zinc plated, with a minimum breaking strength of 5,000 lbf (22.2 kN), and 100% proof tested to 3,600 lbf (16 kN).
- When used as part of a personal fall arrest system, fall arresting forces must not exceed 1,800 lbf (8 kN).
- Capacity is 400 lb (181 kg) including weight of the user plus clothing, tools and other user-borne objects.
- Aramid Fiber is Kevlar® or equivalent material.

2.0 TRAINING

It is the responsibility of the purchaser of the MSA Anchorage Connector Strap to assure that Anchorage Connector Strap users are made familiar with these User Instructions and trained by a competent person in: (1) workplace hazard awareness and hazard identification, evaluation and control; (2) how to properly select, inspect, use, store and maintain the Anchorage Connector Strap; (3) how to determine and acceptably limit free fall distance, total fall distance, and maximum arresting force; (4) proper attachment locations and proper attachment methods including compatibility of connections to reduce the probability of accidental disengagement ("rollout"); (5) how to evacuate from a hazardous space; (6) what to do after a fall to protect the user from injury, including emergency rescue planning and execution; and (7) the consequences of improper use of the equipment and of failure to follow instructions and training. If the Anchorage Connector Strap is to be used for confined space applications, the user must also be trained in accordance with the requirements of OSHA regulation 29 CFR 1910.146 and ANSI Z117.1. Training must be conducted without undue exposure of the trainee to hazards. The effectiveness of training should be periodically assessed (at least annually) and the need for more training or retraining determined. MSA offers training programs. Contact MSA for training information.

3.0 HAZARDS IDENTIFICATION, EVALUATION AND CONTROL



Do not use the MSA Anchorage Connector Strap unless a qualified person has inspected the workplace and determined that identified hazards can neither be eliminated nor exposures to them prevented.

Prior to selecting personal protective equipment, the user must make a workplace assessment of hazards and conditions where the equipment is required. Such assessment must, at a minimum, identify the presence of:

- Hot objects
- Chemicals
- Abrasive surfaces
- Climatic factors
- Sparks
- Electrical hazards
- Moving equipment
- Weather factors
- Flames
- Environmental contaminants
- Moving materials
- Unstable/uneven surfaces
- Slippery surfaces
- Heat-producing operations
- Sharp objects
- Unguarded openings
- Confined space hazards

Foreseeable changes in any of these conditions, taken individually or collectively, must be identified. The materials and construction of the equipment must be considered in the selection process such that these workplace conditions are suitably addressed and responded to. The equipment must match the work situation and workplace environmental factors.

The workplace assessment must identify all paths of intended user movement and all hazards along such paths. The user must identify the required range of mobility in each hazard zone and note the location and distance to all obstructions in potential fall paths. Lateral obstructions which could be contacted in a pendular fall arrest must be noted. An assembly connecting a harness to an anchorage must be selected which will satisfactorily limit total fall distance and allow for dynamic elongation and activation distance of the assembly. If the Anchorage Connector Strap is to be used for confined space entry operations, the workplace assessment must comply with the requirements of OSHA regulation 29 CFR 1910.146 and ANSI Z117.1.

4.0 DESCRIPTION

The MSA Anchorage Connector Strap is a component designed specifically for coupling a single personal fall arrest system to an anchorage. The MSA Anchorage Connector Strap is a temporary, portable, overhead anchorage connector intended for use on such anchorages as beams, girders or pipes.

4.1 ANCHORAGE CONNECTOR STRAP MODELS 505282 & 505298

D-RING (ATTACHMENT ELEMENT FOR CONNECTING SUBSYSTEMS)

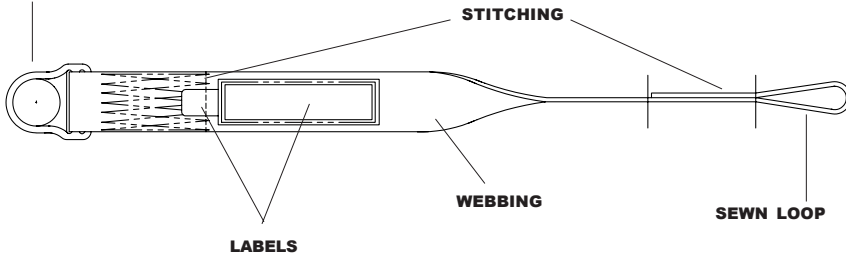

4.2 ANCHORAGE CONNECTOR STRAP MODEL 10023490

D-RING (ATTACHMENT ELEMENT FOR CONNECTING SUBSYSTEMS)

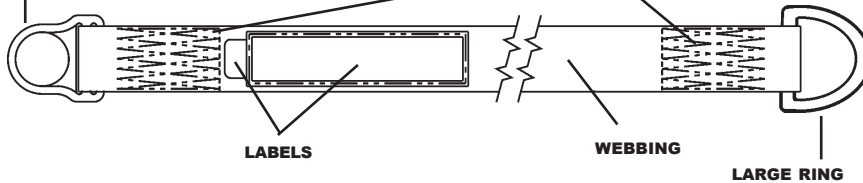

4.3 ANCHORAGE CONNECTOR STRAP MODEL 10023487

D-RING (ATTACHMENT ELEMENT FOR CONNECTING SUBSYSTEMS)

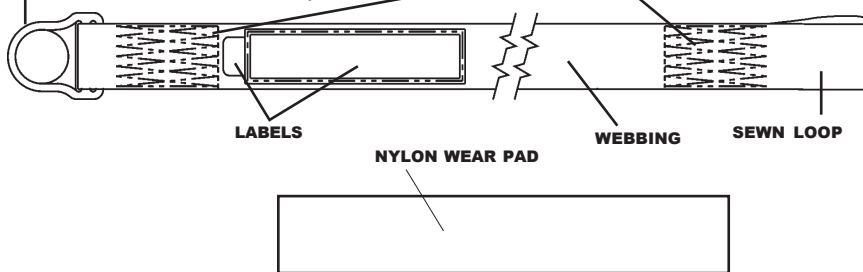

NOTE: Pad shown detached from Model 10023487 for clarity

4.4 ANCHORAGE CONNECTOR STRAP COMPONENTS

4.4.1 STRAP WEBBING:

The Anchorage Connector Strap webbing wraps around the anchorage to create a loop which supports the D-ring attachment element.

4.4.2 LOOP:

A 4 in (102 mm) loop is sewn onto one end of some models of Anchorage Connector Straps. The loop is designed to accommodate the opposite end of the Anchorage Connector Strap during installation on an anchorage. Refer to section 8.2 for installation instructions.

4.4.3 D-RING:

The D-ring is the attachment element for other components and subsystems. Refer to section 5.2 for sizing details.

4.4.4 LARGE RING:

A large D-Ring is sewn onto one end of some models of Anchorage Connector Straps. The ring is designed to accommodate the opposite end of the Anchorage Connector Strap during installation on an anchorage. Refer to section 8.2 for installation instructions.

4.4.5. NYLON WEAR PAD:

The Nylon Wear Pad fits over the Thermatek Anchorage Connector Strap (P/N 10023487). The wear pad protects the strap from abrasive edges.

5.0 SELECTION AND APPLICATIONS

5.1 PURPOSE OF MSA ANCHORAGE CONNECTOR STRAP:

The Anchorage Connector Strap is primarily a component of a personal fall arrest system, serving as an anchorage connector. It may also be used for work positioning, travel restriction, rescue, retrieval, evacuation and confined space entry/exit operations, depending on the associated system components used together with the Anchorage Connector Strap.

Use of the Anchorage Connector Strap must comply with these User Instructions and, further, is subject to approval under the user's safety rules and regulations and by the user's safety director, supervisor, or a qualified safety engineer. Be certain the selection of an Anchorage Connector Strap is suited for the intended use and work environment. If there is any conflict between these User Instructions and other directives or procedures of the user's organization, do not use the Anchorage Connector Strap until such conflicts are resolved. Consult all local, state, and federal Occupational Health and Safety Administration (OSHA) requirements for personal safety equipment. Also refer to the latest revision of ANSI Z359.1 and ANSI A10.14 standards for more information on Anchorage Connector Strap and associated system components. In Canada, refer to provincial and federal regulations.

5.2 SIZING:

The standard length of the MSA Anchorage Connector Strap is 5.0 ft (1.5 m). Other lengths are available on a custom order basis from the factory. Contact MSA for details. The Anchorage Connector Strap must be sized to fit completely around the intended anchorage (e.g. beam, pipe, angle-iron, etc.). The D-ring on the Anchorage Connector Strap is compatible with locking snaphooks up to 0.75 in (20 mm) gate opening size.

5.3 USAGE LIMITATIONS:

The following applications limitations must be considered and planned for before using the MSA Anchorage Connector Strap.

5.3.1 PHYSICAL LIMITATIONS:

The Anchorage Connector Strap is designed for use by one person with a combined total weight no greater than 400 lbs (181 kg), including clothing, tools, and other user-borne objects.

5.3.2 CHEMICAL HAZARDS:

Acidic, alkaline, or other environments with harsh substances may damage the webbing and hardware elements of the Anchorage Connector Strap. Nylon is more resistant to attack by alkaline environments. Polyester is more resistant to attack by acids. If working in a chemically aggressive environment, consult MSA to determine which Anchorage Connector Strap material is better for your specific conditions. When working in the presence of chemicals, more frequent inspection of the Anchorage Connector Strap is required.

5.3.3 HEAT:

Do not use Anchorage Connector Strap in environments with temperatures greater than 185° F (85° C). Protect the Anchorage Connector Strap when used near welding, metal cutting, or other heat producing activities. The Thermatek Anchorage Strap (P/N 10023487) is designed for high heat applications, such as welding and cutting.

5.3.4 CORROSION:

Do not expose the Anchorage Connector Strap to corrosive environments for prolonged periods. Organic substances and salt water are particularly corrosive to metal parts. When working in corrosive environments, more frequent inspection, cleaning and drying of the Anchorage Connector Strap is required. See sections 9, 11 and 12 for cleaning and inspection details.

5.3.5 ELECTRICAL HAZARDS:

Use extreme caution when working near energized electrical sources. Metal hardware will conduct electric current. Maintain a safe working distance (preferably at least 10 ft (3 m)) from electrical hazards.

5.3.6 MOVING MACHINERY:

When working near moving machinery parts (e.g. conveyors, rotating shafts, presses, etc.), maintain a safe working distance from machinery which could entangle clothing, the Anchorage Connector Strap or other personal protective equipment.

5.3.7 SHARP EDGES AND ABRASIVE SURFACES:

When work around sharp edges and abrasive surfaces is unavoidable, use heavy padding or other protective barriers to prevent direct contact.

5.3.8 WEAR AND DETERIORATION:

Any Anchorage Connector Strap which shows signs of excessive wear or deterioration must be removed from use and marked "UNUSABLE" until destroyed. See sections 11 and 12 for detailed inspection procedures.

5.3.9 IMPACT FORCES:

Any Anchorage Connector Strap which has been subjected to the forces of arresting a fall must be immediately removed from service and marked as "UNUSABLE" until destroyed.

6.0 SYSTEMS REQUIREMENTS

The Anchorage Connector Strap is one component of multi-component systems. Without the other necessary components, the Anchorage Connector Strap serves no useful purpose. There are several different types of systems for use at heights and in confined spaces.

6.1 SYSTEM TYPES:

Systems are classified according to their intended purposes. There are six classifications of systems which may be used individually or in combinations. The six basic systems classifications are:

- Fall Arrest
- Personnel-riding
- Evacuation
- Climbing protection
- Restraint
- Rescue

6.1.1 FALL ARREST SYSTEMS:

A fall arrest system is an assembly of components and subsystems, including the necessary connectors, used to arrest the user in a fall from a working height and suspend the user until rescue can be effected. A fall arrest system must always include a harness and connecting means between the harness and an anchorage or anchorage connector. Such connecting means may consist of a lanyard, energy (shock) absorber, fall arrester (rope grab), lifeline, self-retracting lanyard or suitable combinations of these.

6.1.1.1 LANYARD CONNECTING SUBSYSTEM

is the term applied to an assembly, including the necessary connectors, which is comprised of a lanyard and a shock absorber. The lanyard and shock absorber are usually permanently coupled together along with self-locking snaphooks at each end. The subsystem is attached between the fall arrest attachment (back D-ring) of the harness and an anchorage or anchorage connector. The MSA Anchorage Connector Straps identified in Table 1 are compatible for use with fall arrest lanyard connecting subsystems equipped with locking snaphooks up to 0.75 in (20 mm) gate opening size.

6.1.1.2 FALL ARRESTER CONNECTING SUBSYSTEM

is the term applied to an assembly, including the necessary connectors, which is comprised of a fall arrester (rope grab) and a vertical lifeline. Sometimes a lanyard or lanyard with integral shock absorber, including the necessary connectors, is connected to the rope grab. The vertical lifeline must have a lifeline tensioner (counterweight), a connector for anchoring it, and may have a shock absorber. The subsystem is attached between the fall arrest attachment (back D-ring) of the harness and an anchorage or anchorage connector. Fall arrester connecting subsystems are sometimes suitable for use in climbing protection systems. See section 6.1.2. MSA Anchorage Connector Straps identified in Table 1 are suitable for use in fall arrester connecting subsystems.

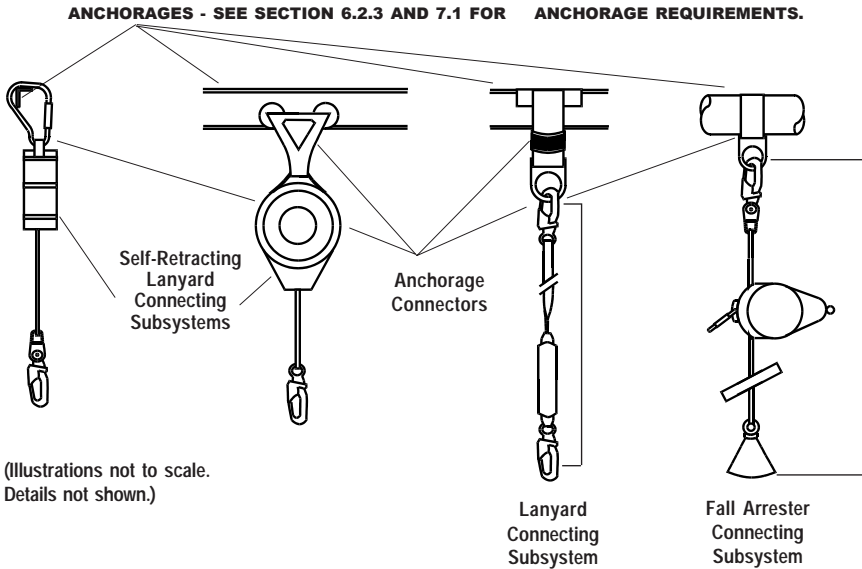

6.2 COMPATIBILITY OF SYSTEM PARTS

6.2.1 COMPATIBILITY OF COMPONENTS AND SUBSYSTEMS:

MSA Anchorage Connector Straps are designed to be used with MSA approved components and connecting subsystems. Use of the Anchorage Connector Strap with products made by others that are not approved in writing by MSA may adversely affect the functional compatibility between system parts and the safety and reliability of the complete

system. Connecting subsystems must be suitable for use in the application (e.g. fall arrest, climbing protection, restraint, rescue or evacuation). MSA produces a complete line of connecting subsystems for each application. Contact MSA for further information. Refer to the manufacturer's instructions supplied with the component or connecting subsystem to determine suitability. For fall arrest applications using MSA Anchorage Connector Straps, the maximum fall arrest force must not exceed 1,800 lbf (8 kN). Contact MSA with any questions regarding compatibility of equipment used with the MSA Anchorage Connector Straps.

6.2.2 COMPATIBILITY OF CONNECTORS:

Connectors, such as D-rings, snaphooks, and carabiners, must be rated at 5,000 lbf (22 kN) minimum breaking strength. MSA connectors meet this requirement. Connecting hardware must be compatible in size, shape, and strength. Non-compatible connectors may accidentally disengage ("rollout"). Always verify that the connecting snaphook or carabiner and the D-ring on the harness or anchorage connector are compatible. Use only self-closing, self-locking snaphooks and carabiners (as defined and required by ANSI Z359.1).

6.2.3 ANCHORAGES AND ANCHORAGE CONNECTORS:

Anchorage for personal fall arrest systems must have a strength capable of supporting a static load, applied in directions permitted by the system, of at least: (a) 3,600 lbf (16 kN) when certification exists, or (b) 5,000 lbf (22.2 kN) in the absence of certification. See ANSI Z359.1 for definition of certification. When more than one personal fall arrest system is attached to an anchorage, the anchorage strengths set forth in (a) and (b) must be multiplied by the number of systems attached to the anchorage. See ANSI Z359.1, section 7.2.3. This requirement is consistent with OSHA requirements under 20 CFR 1910, Subpart F, Section 1910.66, Appendix C. In addition, it is recommended that the user of personal fall arrest systems refer to ANSI Z359.1, Section 7, for important considerations in equipment selection, rigging, use, and training.

7.0 PLANNING THE USE OF SYSTEMS

Perform the hazard identification and evaluation described in section 3 of these instructions. Then plan the system(s) before starting work. Consider all possible paths of user movement and all factors that could affect the user's safety before, during, and after a fall anywhere along these paths. A qualified person must select the components, materials, anchorage and anchorage connectors to match the system application, the work, workplace hazards, and the environment. Consider the following points when planning the system(s).

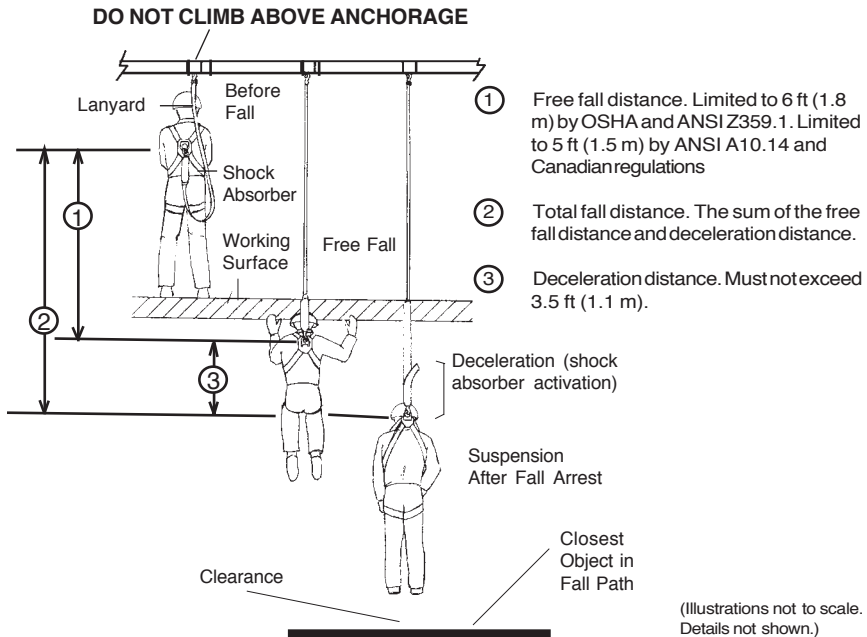

7.1 USER MOVEMENTS:

Identify all necessary movements of the user and the materials and equipment needed to perform the planned work. Plan for avoidance of the crossing or tangling of connecting subsystems of two or more workers. Anticipate user movements that might introduce hazards of the connecting subsystem passing under, about or between body parts or invite the user to clamp, knot or otherwise prevent the connecting subsystem from functioning properly. Establish controls to prevent these occurrences.

7.2 PENDULUM (SWING) FALLS:

Swing falls can occur when the system is not anchored directly above the user. The force of striking an object in a pendular motion can cause serious injury. Always minimize swing falls by working as directly below the anchorage point as possible.

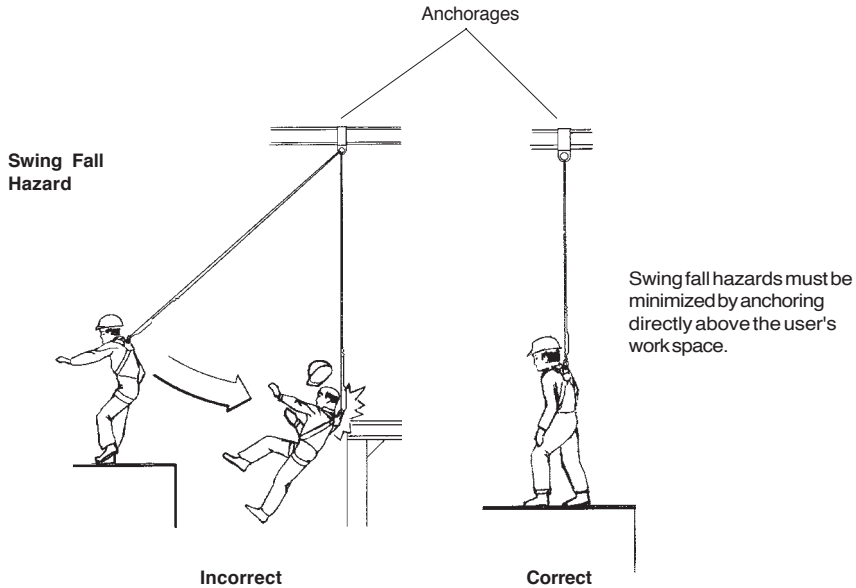

7.3 CLEAR SPACE IN FALL PATH:

Make certain that enough clearance is available in all potential fall paths to prevent striking an object. The amount of clearance needed depends upon the type of connecting subsystem used, and the location of the anchorage. Consult the manufacturer's instructions for the particular connecting subsystem or component for clearance needed.

7.4 HAZARDS IDENTIFIED IN WORKPLACE ASSESSMENT:

All hazards of the type set forth in section 3 of these instructions must be addressed and suitable controls planned and implemented. For example, if work must be performed near unavoidable sharp edges, plan to protect against cutting by use of heavy padding or other means of covering the sharp edge.

7.5 RESCUE AND EVACUATION:

The user must have a rescue plan and the means at hand to implement it. The plan must take into account the equipment and special training necessary to effect prompt rescue under all foreseeable conditions. If the rescue be from a confined space, the provisions of OSHA regulation 1910.146 and ANSI Z117.1 must be taken into account. Although a rescue plan and the means to implement it must always be in place, it is a good idea to provide means for evacuation without assistance of others. This will usually reduce the time to get to a safe place and reduce or prevent the risk to rescuers.

8.0 USAGE

8.1 INSPECTION BEFORE EACH USE:

Inspect the Anchorage Connector Strap to verify that it is in serviceable condition. Examine every inch of the straps for severe wear, cuts, burns, frayed edges, abrasion, or other damage. Examine stitching for any pulled, loose, or torn stitches. See section 11 for inspection details. Do not use Anchorage Connector Strap if inspection reveals an unsafe condition.

CAUTION

The Thermatek strap uses a nylon wear pad to protect the Aramid Fiber from abrasion only; wear pad must be on the strap during use. Replacement wear pads are available.

8.2 INSTALLATION OF THE ANCHORAGE CONNECTOR STRAP

8.2.1 ANCHORAGE PREPARATION:

Begin by preparing the anchorage (e.g. beam, girder, pipe, etc.). The anchorage should be clean and dry before installing the Anchorage Connector Strap. If the anchorage has any exposed edges smaller than 1/32 in (0.8 mm) radius, cover the edges with protective padding before installing the Anchorage Connector Strap. The padding should be stabilized to prevent shifting while the Anchorage Connector Strap is in use.

CAUTION

When installing or removing the Anchorage Connector Strap, limit exposure to fall hazards. A separate independent fall arrest system may be required.

8.2.2 INSTALLATION SEQUENCE FOR MODELS 505282, 505298, & 10023487:

Step 1: Wrap the Anchorage Connector Strap around the anchorage. More than one wrap may be possible on smaller anchorage structures. The label must face upward when passing over the anchorage.

Step 2: Pull the D-ring of the Anchorage Connector Strap through the loop on the other end. Cinch tight.

Step 3: Verify that the Anchorage Connector Strap is stable and not exposed to sharp edges or other hazards. Verify that the D-ring is pulled completely through the loop of the Anchorage Connector Strap and will hang freely down in the direction in which loads will be applied.

NOTE: A means of remotely connecting and disconnecting an Anchorage Connector Strap is available from MSA. Contact your distributor or the factory for details of the MSA Remote Connect/Disconnect System (Model 501443).

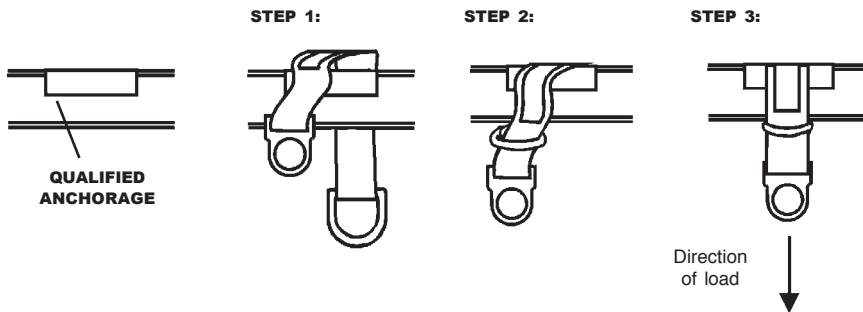

CAUTION

Do not leave the Anchorage Connector Strap installed in environments which could cause damage or deterioration to the product. Refer to sections 9, 11 and 12 for care and inspection details. Do not leave unattended loads on the Anchorage Connector Strap.

8.2.3 INSTALLATION SEQUENCE FOR MODEL 10023490

- Step 1:** Wrap the Anchorage Connector Strap around the anchorage. More than one wrap may be possible on smaller anchorage structures. The label must face upward when passing over the anchorage.
- Step 2:** Pull the D-ring of the Anchorage Connector Strap through the large ring on the other end. Cinch tight.
- Step 3:** Verify that the Anchorage Connector Strap is stable and not exposed to sharp edges or other hazards. Verify that the D-ring is pulled completely through the loop of the Anchorage Connector Strap and will

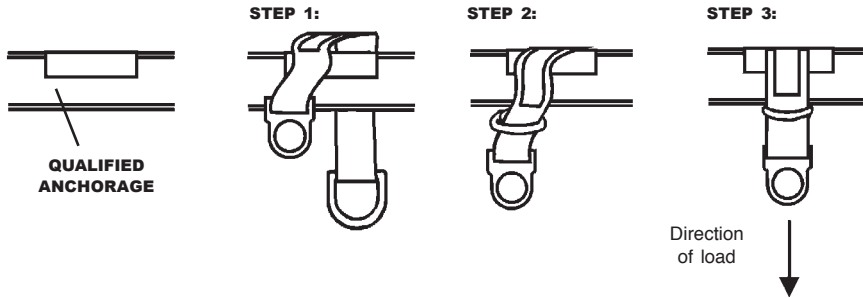

hang freely down in the direction in which loads will be applied.

8.3 MAKING CONNECTIONS:

When using a snaphook or carabiner to connect to an anchorage or when coupling components of the system together, be certain accidental disengagement (rollout) cannot occur. Rollout is possible when interference between a carabiner and the mating connector causes the carabiner's gate or keeper to accidentally open and release. Rollout occurs when a carabiner is snapped into an undersized ring such as an eye bolt or other non-compatibly shaped connector. Only self closing, self-locking snaphooks and carabiners should be used to reduce the possibility of rollout when making connections. Do not use snaphooks or connectors that will not completely close over the attachment object. Do not make knots in a lanyard. Do not hook a lanyard back onto itself. Snaphooks and carabiners must not be connected to each other. Do not attach two snaphooks or carabiners into one D-ring. Do not attach snaphooks or carabiners directly to a horizontal lifeline. Always follow the manufacturer's instructions supplied with each system component.

8.4 REMOVAL OF THE ANCHORAGE CONNECTOR STRAP:

Before attempting removal of the Anchorage Connector Strap, disconnect all loads and attachment elements from the Anchorage Connector Strap D-ring. Pull the D-ring back through the loop and unwrap the Anchorage Connector Strap from the anchorage. Return the Anchorage Connector Strap to the appropriate person in the user's organization for cleaning, inspection and storage.

9.0 CARE, MAINTENANCE AND STORAGE**9.1 CLEANING INSTRUCTIONS:**

Clean the Anchorage Connector Strap with a solution of water and mild laundry detergent. Dry hardware with a clean cloth and hang to air dry. Do not speed dry with heat. Excessive accumulation of dirt, paint or other foreign matter may prevent proper function of the Anchorage Connector Strap, and in severe cases may weaken the webbing. Questions concerning Anchorage Connector Strap conditions and cleaning should be directed to MSA.

9.2 MAINTENANCE AND SERVICE:

Equipment which is damaged or in need of scheduled maintenance must be tagged as "UNUSABLE" and removed from service. Corrective maintenance (other than cleaning) and repair, such as replacement of elements, must be performed by MSA. Do not attempt repairs.

9.2.1 REPLACEMENT OF WEAR PAD

The nylon wear pad on Model 10023487 is used for abrasion protection only. If this wear pad needs to be replaced, follow these procedures:

- Step 1:** Starting at the D-Ring cut down the length of the tubular webbing with a pair of scissors. Stop one (1) inch from the stitching that connects the wear pad to the anchor strap.
- Step 2:** Cut the wear pad off at this point, leaving the stitched portion attached to the anchor strap. The remaining tubular flap will prevent replacement wear pads from accidentally slipping off.
- Step 3:** Starting from Sewn Loop slide replacement wear pad over the anchorage strap. Continue slidding until wear pad touches the D-Ring, completely exposing the tubular flap.

The new wear pad can slide back and forth on the anchor strap. The tubular flap remaining from the original wear pad prevents any subsequent wear pads from falling off accidentally.

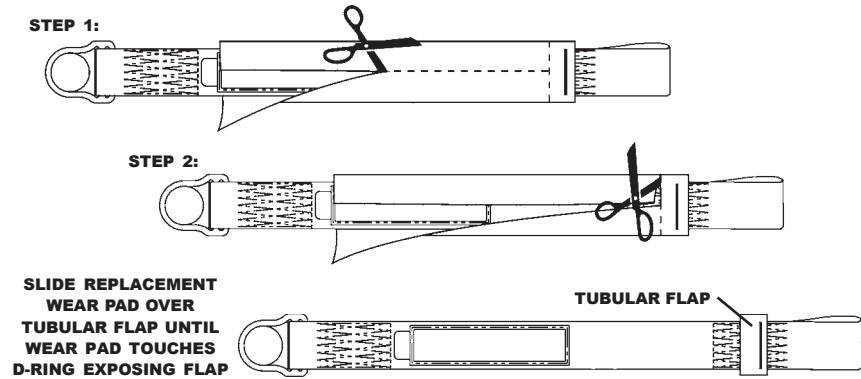

9.3 STORAGE:

Store the Anchorage Connector Strap in a cool, dry and clean place out of direct sunlight. Avoid areas where heat, moisture, light, oil, and chemicals or their vapors or other degrading elements may be present. Equipment which is damaged or in need of scheduled maintenance should not be stored in the same area as usable equipment. Heavily soiled, wet, or otherwise contaminated equipment should be properly maintained (e.g. dried and cleaned) prior to storage. Prior to using equipment which has been stored for long periods of time, a Formal Inspection should be performed by a competent person.

10.0 MARKINGS AND LABELS

10.1

The following labels must be present, legible and securely attached to the Anchorage Connector Strap. The Formal Inspection Grid must be punched with a date (month/year) within the last six months. If not, remove the Anchorage Connector Strap from use and mark it as "UNUSABLE" until a Formal Inspection is performed in accordance with section 12. See section 4 for location of labels.





MSA Corporate Headquarters
 P.O. Box 426
 Pittsburgh, PA 15230
 1-800-672-2222

**ANCHORAGE
 CONNECTORSTRAP**

Capacity 400 lbs (181 kg)
 Breaking Strength 5,000 lbf (22.2 kN)
 Meets ANSI Z359.1

P/N **Material**
 505282 Nylon
 10023490 Nylon

INSPECTION GRID

	J	F	M	A	M	J	J	A	S	O	N	D
1 st												
2 nd												
3 rd												
4 th												
5 th												

PUNCH GRID WITH BALL POINT PEN ON DATE OF FIRST USE AND AFTER EACH FORMAL INSPECTION BY COMPETENT PERSON.

CAUTION

THIS PRODUCT IS FOR PERSONAL FALL ARREST USE ONLY. IT IS NOT A SLING AND IS NOT FOR MATERIALS HANDLING. READ AND HEED SEPARATE USER INSTRUCTION (P/N 622792) BEFORE USING. THE INSTRUCTIONS MUST BE AVAILABLE FOR YOUR USE. IF YOU HAVE ANY QUESTIONS, CONSULT YOUR SUPERVISOR.

Atención: Si usted no puede leer el inglés o si usted no comprende estas instrucciones, favor de consultar su director de seguridad o su supervisor.

Attention: Si vous ne pouvez pas lire l'anglais, ou si vous ne comprenez pas les instructions, consultez votre directeur de sécurité ou votre superviseur.

Achtung: Wenn Sie nicht Englisch lesen können und diese Anweisungen nicht verstehen, dann fragen Sie bitte Ihren Sicherheitsdirektor oder Ihren Aufseher.

Attenzione: Se non leggete l'inglese o non capite queste istruzioni, per favore rivolgete Vi al Vostro Direttore, responsabile della "Sicurezza sul Lavoro" o al Vostro diretto superiore.

USE: Pass this STRAP over suitable anchorage. This label must face upward when passing over anchorage. Anchorage strength must be at least 5,000 lbf (22.2 kN). Insert D-ring through loop or large ring. Cinch down until strap is tight. Use protective padding (softener) if installing over edge with radius of 1/32 in. (0.8 mm) or less. Do not install where product may be exposed to electrical sources, high heat or harsh chemicals. Use only for connection of compatible snaphook or carabiner to D-ring. Install to overhead anchorage to protect against swing falls. Only connect one connector to the D-ring of this strap.

INSPECTION: Inspection is required by user before each use and by competent person at least once a year. Inspect webbing for torn stitches, broken or abraded fibers, frayed edges, burns, weld spatter, cuts or tears. Inspect D-ring for cracks, nicks, dents, corrosion, pits, excess wear or deformation. Remove from use:

- if product does not pass inspection
- if product is subjected to impact load

If removed from use, mark or tag this product as "UNUSABLE" until repaired or destroyed.

P/N 62277, Rev. C



MSA Corporate Headquarters
 P.O. Box 426
 Pittsburgh, PA 15230
 1-800-672-2222

**ANCHORAGE
 CONNECTOR STRAP**

Capacity 400 lbs (181 kg)
 Breaking Strength 5,000 lbf (22.2 kN)
 Meets ANSI Z359.1

P/N **Material**
 505298 Polyester
 10023497 Aramid Fiber

INSPECTION GRID

YR	J	F	M	A	M	J	J	A	S	O	N	D
1 st												
2 nd												
3 rd												
4 th												
5 th												

PUNCH GRID WITH BALL POINT PEN ON MONTH OF FIRST USE AND AFTER EACH FORMAL INSPECTION BY COMPETENT PERSON.

CAUTION

THIS PRODUCT IS FOR PERSONAL FALL ARREST USE ONLY. IT IS NOT A SLING AND IS NOT FOR MATERIALS HANDLING. READ AND HEED SEPARATE USER INSTRUCTION (P/N 622792) BEFORE USING. THE INSTRUCTIONS MUST BE AVAILABLE FOR YOUR USE. IF YOU HAVE ANY QUESTIONS, CONSULT YOUR SUPERVISOR.

Atención: Si usted no puede leer el inglés o si usted no comprende estas instrucciones, favor de consultar su director de seguridad o su supervisor.

Attention: Si vous ne pouvez pas lire l'anglais, ou si vous ne comprenez pas les instructions, consultez votre directeur de sécurité ou votre superviseur.

Achtung: Wenn Sie nicht Englisch lesen können und diese Anweisungen nicht verstehen, dann fragen Sie bitte Ihren Sicherheitsdirektor oder Ihren Aufseher.

Attenzione: Se non leggete l'inglese o non capite queste istruzioni, per favore rivolgete Vi al Vostro Direttore, responsabile della "Sicurezza sul Lavoro" o al Vostro diretto superiore.

USE: Pass this STRAP over suitable anchorage. This label must face upward when passing over anchorage. Anchorage strength must be at least 5,000 lbf (22.2 kN). Insert D-ring through loop. Cinch down until strap is tight. Use protective padding (softener) if installing over edge with radius of 1/32 in. (0.8 mm) or less. Do not install where product may be exposed to electrical sources, high heat or harsh chemicals. Use only for connection of compatible snaphook or carabiner to D-ring. Install to overhead anchorage to protect against swing falls. Only connect one connector to the D-ring of this strap.

INSPECTION: Inspection is required by user before each use and by competent person at least once a year. Inspect webbing for torn stitches, broken or abraded fibers, frayed edges, burns, weld spatter, cuts or tears. Inspect D-ring for cracks, nicks, dents, corrosion, pits, excess wear or deformation. Remove from use:

- if product does not pass inspection
- if product is subjected to impact load

CAUTION

NOTE: Thermatek™ Model 10023487

This model is designed for use near welding and cutting operations. The Thermatek strap uses a nylon wear pad to protect the aramid fiber from abrasion; wear pads must be used. Replacement wear pads are available. If there is severe charring on the aramid material, remove from use.

If removed from use, mark or tag this product as "UNUSABLE" until repaired or destroyed.

P/N 62278, Rev. H

11.0 INSPECTION BEFORE EACH USE

11.1 INSPECTION FREQUENCY:

The Anchorage Connector Strap must be inspected by the user before each use and, additionally, by a competent person other than the user at intervals of no more than six months. The competent person inspection is referred to as Formal Inspection. See section 12 for Formal Inspection procedures.



If the Anchorage Connector Strap has been subjected to fall arrest or impact forces, it must be immediately removed from service and marked as "UNUSABLE" until destroyed.

11.2 INSPECTION STEPS

Step 1: Inspect the Anchorage Connector Strap labels to verify that they are present and legible. See section 4 for location of labels for each model. See section 10 for the specific labels that should be present and the information contained on those for the model number shown on page one (1) of these instructions. Check the Formal Inspection Grid to be sure a Formal Inspection has been performed within the last six months. If the Grid does not indicate that a Formal Inspection has been performed within the last six months (by being punched), or if any labels are missing or illegible, remove the Anchorage Connector Strap from use and mark it as "UNUSABLE" until a Formal Inspection is performed by a competent person.

Step 2: Inspect every square inch of the webbing and stitching for evidence of defects or damage, including: cuts, fraying, pulled or broken threads, loose or torn threads, abrasion, excessive wear or elongation, altered or missing webbing or stitching, knots, burns, and damage from heat or chemical attack.

NOTE: Aramid webbing is engineered to withstand high heat but may burn at very high temperatures. Replace Thermatek anchorage straps if they show severe charring or holes.

Step 3: Inspect the D-ring for deformation, fractures, cracks, corrosion, deep pitting, sharp edges, cuts, deep nicks, and evidence of excessive heat or chemical exposures.

Step 4: Inspect the plastic labels for their presence and legibility.

Step 5: Inspect each component and subsystem of the complete system in accordance with the associated manufacturer's instructions. See section 6 for a description of the make-up of the different types of subsystems and systems.

11.3 CORRECTIVE ACTION:

When inspection in accordance with section 11.2 reveals signs of inadequate maintenance, the Anchorage Connector Strap must be immediately removed from service and marked as "UNUSABLE" until destroyed or subjected to corrective maintenance by the user's organization in accordance with section 9. Defects, damage, excessive wear, malfunction, and aging are generally not repairable. If detected, immediately remove the Anchorage Connector Strap from use and mark it as "UNUSABLE" until destroyed. For final disposition, submit the Anchorage Connector Strap to a competent person who is authorized to perform Formal Inspection. If there is any question as to reparability, contact MSA or a service center authorized in writing by MSA before further use of the product.



Only MSA or parties authorized in writing may make repairs to this equipment.

12.0 FORMAL INSPECTION

12.1 FORMAL INSPECTION FREQUENCY:

The Anchorage Connector Strap must be formally inspected by a competent person other than the user at intervals of no more than six months. (The qualifications of a competent person are established by OSHA.) If the product is exposed to severe working conditions, more frequent formal inspections may be required. The frequency of inspection by a

competent person should be established by the user's organization based on such factors as the nature and severity of workplace conditions, modes of use, and exposure time of the equipment. The competent person should perform a methodical and thorough visual and tactile inspection by following the inspection procedure in section 12.3. The inspection results should be recorded in the Formal Inspection Log and retained for reference. In addition, if the Anchorage Connector Strap passes Formal Inspection, the competent person, using a ballpoint pen, should punch the date (month and year) of Formal Inspection on the grid supplied with the labels on each product. The user should never punch this grid; however, the user should check it before each use to be sure a Formal Inspection has been performed within the last six months.

12.2 CONTROL OF EQUIPMENT:

The user's organization should establish and enforce a policy and procedure whereby any Anchorage Connector Strap that is found to be defective, damaged, or in need of maintenance be immediately removed from use, marked as "UNUSABLE" and immediately thereafter submitted to custody of the competent person responsible for Formal Inspection. This has the benefits that: 1) defective equipment is secured from further use until proper action is taken; 2) uniform standards are applied for determining whether the equipment is acceptable or not acceptable for further use; 3) uniform methods of cleaning and other maintenance are applied; and 4) there is a central point for evaluation of conditions that may be recurring and require preventive measures such as coordination with the equipment manufacturer, selection of alternate equipment, additional training of equipment users, or changes to the workplace conditions.

12.3 FORMAL INSPECTION PROCEDURE:

The Formal Inspection Procedure is similar to the user's inspection before each use described in section 11. However, it differs in three important respects, namely: 1) it is performed by a competent person other than the user who is trained and authorized to perform Formal Inspection for the user's organization; 2) it is more detailed and is methodically recorded on a Formal Inspection Log that is kept on file for future reference; and 3) it results in final disposition of the equipment as either "acceptable" or as "not acceptable" followed by destruction of the product.

There are three forms that are important to the Formal Inspection Procedure. They are the Formal Inspection Diagram ("DIAGRAM"), the Formal Inspection Log ("LOG"), and the Formal Inspection Checklist and Codes ("CHECKLIST"). These forms relate and refer to each other so it is necessary to understand their purposes and uses before discussing the inspection procedure.

12.3.1 DIAGRAM:

This is a set of line drawings of the Anchorage Connector Strap. Each has numbered callouts of the parts. The numbers called out in the DIAGRAM correspond to those shown on the column titled "INSP. POINT" (inspection point) on the LOG.

12.3.2 LOG:

This is the form to be used to record observations made during the Formal Inspection. The Model No., Serial No. and Date Made are recorded by the inspector from the label set. The formal inspector's name and the inspection date are entered by the inspector. The "Disposition" entry is the last entry made on this form after all observations have been recorded. The entry is either "Acceptable" ("PASS") or "Not Acceptable" ("FAIL"). The columns on the LOG are as follows:

INSP. POINT - Inspection point. The Anchorage Connector Strap part designated in the callouts on the DIAGRAM.

DESCRIPTION - Name of the Anchorage Connector Strap inspection point.

QTY/ACS - Quantity per Anchorage Connector Strap. The quantity of each Anchorage Connector Strap inspection point that must be inspected.

COND. - Condition. The condition of the Anchorage Connector Strap part is indicated here by entry of the appropriate Condition Code shown on the CHECKLIST (e.g. M0, P2, etc.). Alternatively, the inspector may simply enter "FAIL" if a defective condition exists and make no entry if no defect exists.

OVERALL ASSESS. - Overall assessment. The inspector's evaluation of the overall acceptability or non-acceptability of the part category (e.g. webbing, stitching, metallic, plastic). The appropriate Overall Assessment Code defined on the CHECKLIST is entered here (e.g. MA, PN, etc.). Alternatively, the inspector may simply enter "FAIL" if a defective condition exists and make no entry if no defect exists.

COMMENTS - Indicate pertinent inspector observations here.

12.3.3 CHECKLIST AND CODES:

This is a table which categorizes the different types of Anchorage Connector Strap. For each of these categories that are applicable to a specific product, the formal inspector checks the Anchorage Connector Strap parts for each of the associated conditions (e.g. deformation, corrosion, etc.). The codes for the detected conditions are entered in the Condition column on the LOG (e.g. M1, P0, etc.). Overall assessment codes are given, along with the criteria for assigning them, so the inspector can decide if the Anchorage Connector Strap is acceptable or not acceptable for further use (e.g. MA, MN, PA, PN). Alternatively, instead of using these codes, the inspector may simply enter "FAIL" if a defective condition exists and make no entry if no defect exists.

12.3.4 FORMAL INSPECTION PROCEDURAL STEPS:

- Step 1:** Record on the LOG the Model No., Serial No. and Date Made information shown on the product label set. Record the inspector's name and inspection date.
- Step 2:** Arrange the Anchorage Connector Strap so the parts to be inspected are readily visible.
- Step 3:** Starting with the parts shown on the LOG, inspect each part (inspection point) one at a time. Refer to the DIAGRAM for identification of each inspection point. Each part must be inspected for the possible presence of the conditions shown on the CHECKLIST. Enter in the Condition column on the LOG the proper Condition Code (listed on the CHECKLIST) or "FAIL" if a defect exists. If there is any question whether the product condition has materially changed since the last Formal Inspection, retrieve and review the prior Formal Inspection records for the specific product.
- Step 4:** Determine whether the part (inspection point) is acceptable or not acceptable. If an inspection point has a defective condition, enter in the Overall Assessment column of the LOG the proper code taken from the CHECKLIST or simply "FAIL."
- Step 5:** Determine disposition of the Anchorage Connector Strap. If in step 4 it has been determined that the Anchorage Connector Strap is not acceptable, enter "N" or "FAIL" in the Disposition space on the LOG. In addition, a notation should be made in this space as to whether the Anchorage Connector Strap is to be destroyed, returned to manufacturer/distributor, etc.
- Step 6:** If in step 4 it has been determined that the Anchorage Connector Strap is acceptable for further use, enter "A" or "PASS" in the Disposition space on the LOG.
- Step 7:** File the LOG for future reference.

12.4 FORMAL INSPECTION CHECKLIST AND CODES

TYPE OF PART INSPECTED	CONDITION	COND. CODE	OVERALL ASSESS. CODE	LEGEND
Webbing	Cuts/fraying	W1	WA - (Webbing acceptable)	Disposition: A - (Acceptable) N - (Not acceptable) Enter "A" (or "PASS") or "N" (or "FAIL") in Disposition blank on Formal Inspection Log.
	Abrasion/wear	W2		
	Partially missing/altered	W3		
	Burns/heat exposure	W4	WN - (Webbing not acceptable)	
	Chemical exposure	W5		
	Knotted/elongated	W6		
	Other	W7		
	No visible change	W0		
Stitching	Cut/pulled/loose thread	S1	SA - (Stitching acceptable)	Criteria for disposition of "N" (Not acceptable):
	Abrasion/wear	S2		
	Partially missing/altered	S3		
	Burns/heat exposure	S4	SN - (Stitching not acceptable)	
	Chemical exposure	S5		
	Other	S6		
	No visible change	S0		
Metallic	Deformed/fractured	M1	MA - (Metallic acceptable)	If there is one or more Overall Assessment Code of "N" type (e.g. WN, SN, MN, PN).
	Corroded/deep pits	M2		
	Missing/loose	M3		
	Heat exposure	M4		
	Chemical exposure	M5		
	Burrs/sharp edges	M6	MN - (Metallic not acceptable)	
	Cuts/deep nicks	M7		
	Malfunction	M8		
	Other	M9		
	No visible change	M0		
Plastic	Cut/broken/deformed	P1	PA - (Plastic acceptable)	
	Wear damage	P2		
	Missing/loose	P3		
	Burns/heat exposure	P4	PN - (Plastic not acceptable)	
	Chemical exposure	P5		
	Other	P6		
	No visible change	P0		

12.5 FORMAL INSPECTION DIAGRAM

12.5.1 ANCHORAGE CONNECTOR STRAP: MODELS 505282 AND 505298

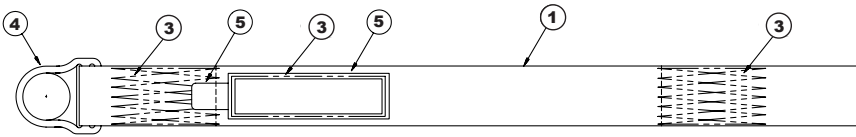

12.5.2 ANCHORAGE CONNECTOR STRAP: MODEL 10023490

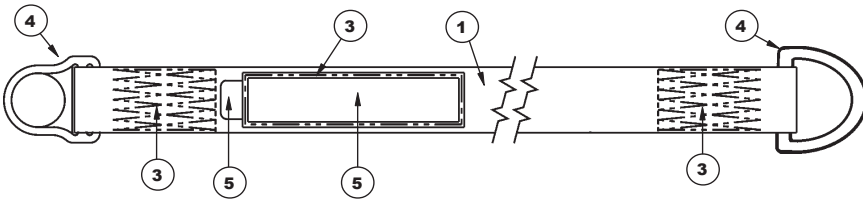

12.5.3 ANCHORAGE CONNECTOR STRAP: MODEL 10023487

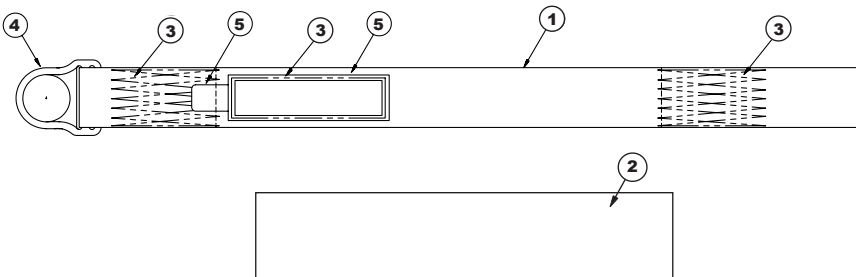

NOTE: Pad shown detached from Model 10023487 for clarity

12.6 FORMAL INSPECTION LOG FOR MSA ANCHORAGE CONNECTOR STRAP

Model No. 505298 Inspector J. W. Doe
 Serial No. 012345 Inspection Date 6/4/98
 Date Made 2/98 Disposition N - See item 1, Destroy Anchorage
Connector Strap.

INSP. POINT	DESCRIPTION	QTY / ACS	COND. (a)	OVERALL ASSESS. (a)	COMMENTS
FABRIC (FIBROUS) PARTS					
WEBBING (STRAPS)					
1	Strap	1	W1	WN	1" cut in webbing, destroy strap
2	Wear Pad (P/N 10023487)	1	W0	WA	
STITCHING					
3	Strap	3	S0	SA	
METALLIC PARTS					
4	D-Ring	1	M0	MA	
4	D-Rings (P/N 10023490)	2	M0	MA	
PLASTIC PARTS					
5	Labels	2	P0	PA	

(a) Optional simplified PASS/FAIL inspection format: Whenever an acceptable condition is found, the entry in the COND. and OVERALL ASSESS. columns may be left blank. Whenever a defective condition is found, enter "FAIL." The inspection may end upon detection of a single defective condition.

(b) Blank copies of this LOG, with associated CHECKLIST and DIAGRAM, are available from MSA. Call Toll Free (800) 722-1231.

**12.6 FORMAL INSPECTION LOG FOR
MSA ANCHORAGE CONNECTOR STRAP**

Model No. _____ Inspector _____

Serial No. _____ Inspection Date _____

Date Made _____ Disposition _____

INSP. POINT	DESCRIPTION	QTY / ACS	COND. (a)	OVERALL ASSESS. (a)	COMMENTS
FABRIC (FIBROUS) PARTS					
	WEBBING (STRAPS)				
1	Strap	1			
2	Wear Pad (P/N 10023487)	1			
	STITCHING				
3	Strap	3			
METALLIC PARTS					
4	D-Ring	1			
4	D-Rings (P/N 10023490)	2			
PLASTIC PARTS					
5	Labels	2			

(a) Optional simplified PASS/FAIL inspection format: Whenever an acceptable condition is found, the entry in the COND. and OVERALL ASSESS. columns may be left blank. Whenever a defective condition is found, enter "FAIL." The inspection may end upon detection of a single defective condition.

(b) Blank copies of this LOG, with associated CHECKLIST and DIAGRAM, are available from MSA. Call Toll Free (800) 722-1231.

WARRANTY

Express Warranty – MSA warrants that the product furnished is free from mechanical defects or faulty workmanship for a period of one (1) year from first use or eighteen (18) months from date of shipment, whichever occurs first, provided it is maintained and used in accordance with MSA's instructions and/or recommendations. Replacement parts and repairs are warranted for ninety (90) days from the date of repair of the product or sale of the replacement part, whichever occurs first. MSA shall be released from all obligations under this warranty in the event repairs or modifications are made by persons other than its own authorized service personnel or if the warranty claim results from misuse of the product. No agent, employee or representative of MSA may bind MSA to any affirmation, representation or modification of the warranty concerning the goods sold under this contract. MSA makes no warranty concerning components or accessories not manufactured by MSA, but will pass on to the Purchaser all warranties of manufacturers of such components. **THIS WARRANTY IS IN LIEU OF ALL OTHER WARRANTIES, EXPRESS, IMPLIED OR STATUTORY, AND IS STRICTLY LIMITED TO THE TERMS HEREOF. MSA SPECIFICALLY DISCLAIMS ANY WARRANTY OF MERCHANTABILITY OR FITNESS FOR A PARTICULAR PURPOSE.**

Exclusive Remedy - It is expressly agreed that the Purchaser's sole and exclusive remedy for breach of the above warranty, for any tortious conduct of MSA, or for any other cause of action, shall be the repair and/or replacement, at MSA's option, of any equipment or parts thereof, that after examination by MSA are proven to be defective. Replacement equipment and/or parts will be provided at no cost to the Purchaser, F.O.B. Purchaser's named place of destination. Failure of MSA to successfully repair any nonconforming product shall not cause the remedy established hereby to fail of its essential purpose.

Exclusion of Consequential Damages - Purchaser specifically understands and agrees that under no circumstances will MSA be liable to Purchaser for economic, special, incidental, or consequential damages or losses of any kind whatsoever, including but not limited to, loss of anticipated profits and any other loss caused by reason of the non-operation of the goods. This exclusion is applicable to claims for breach of warranty, tortious conduct or any other cause of action against MSA.

For additional information, please contact the Customer Service Department at 1-800-MSA-2222 (1-800-672-2222).

THERMATEK™ is a registered trademark of MSA.

KEVLAR® is a registered trademark of the DuPont Corporation.



For More Information: Call (1-800-MSA-2222) or Visit Our Website at (www.MSAnet.com)

MSA

Be Sure.
Choose MSA.

MINE SAFETY APPLIANCES COMPANY
PITTSBURGH, PENNSYLVANIA, U.S.A. 15230