

Cylinder Valve

MAINTENANCE AND REPAIR

For More Information, call 1-800-MSA-2222 or Visit Our Website at www.MSAnet.com



MINE SAFETY APPLIANCES COMPANY
PITTSBURGH, PENNSYLVANIA, U.S.A. 15230

CYLINDER VALVE COMPONENTS					
Item	Part No.	Description	Item	Part No.	Description
1	809872	3AL Aluminum, 45 cu ft.*	19	488771	Valve Body (4500 psig) (Current Design)
	469619	Hoop-wound, 45 cu ft.		488772	Valve Body (2216 psig) (Current Design)
	807586	L-30 Stealth Carbon-wrapped		495743	Valve Body (3000 psig) Valve Body (180°)
	816115	L-30+ Stealth Carbon-wrapped, 60 cu ft.			Valve Body (Prior Design)
	807587	H-30 Stealth Carbon-wrapped, 45 cu ft.	20	95019	Air Pressure Gauge (2216/3000 psig) (Prior Design)
	807570	H-45 Stealth Carbon-wrapped, 66 cu ft.		95278	Air Pressure Gauge (2216/3000 psig)
	10035644	H-45 Low-Profile, Stealth Carbon-wrapped, 66 cu ft.		473250	Air Pressure Gauge (4500 psig)
	807588	H-60 Stealth Carbon-wrapped, 88 cu ft.	21	66835	O-Ring (Prior Design)
	814806	3AL Aluminum, 45 cu ft.*	22	454544	Gland Ring (Prior Design)
	81119	Hoop-wound, 45 cu ft.	23	801131	Gauge Guard
	816970	L-30 Stealth Carbon-wrapped		801140	Gauge Guard (Prior Design)
	816974	L-30+ Stealth Carbon-wrapped, 60 cu ft.	KITS		
	816972	H-30 Stealth Carbon-wrapped, 45 cu ft.	24	482225	Blow Out Disc Kit (2216 psig)
	816973	H-45 Stealth Carbon-wrapped, 66 cu ft.		482226	Blow Out Disc Kit (4500 psig)
	10044832	H-45 Low-Profile, Stealth Carbon-wrapped, 66 cu ft.		494928	Blow Out Disc Kit (3000 psig)
	816971	H-80 Stealth Carbon-wrapped, 88 cu ft.	25	473957	Packing Gland Kit (Prior Design)
2	804922	Warning Label	CYLINDER VALVE ASSEMBLIES (LOW PRESSURE)		
3	471368	Label Lot No.		809872	45 CU. FT. Aluminum (2216 psig) (Rated 30 Min.) (Current)
4	492845	Caution/Warning Label (3000 psig)		469619	45.5 CU. FT. Hoop Wound Aluminum (2216 psig) (Rated 30 Min.) (Current)
5	488894	Valve Assembly (2216 psig)		807586	66 CU. FT. Composite Carbon (2216 psig) (Rated 30 Min.) (Current)
	494884	Valve Assembly (3000 psig)		816115	60 CU. FT. Composite III Carbon (3000 psig) (Rated 30 Min.) (Prior)
	488899	Valve Assembly (4500 psig)	CYLINDER AND VALVE ASSEMBLIES (HIGH PRESSURE)		
6	80416	Cylinder Valve Inlet Tube		807587	45 CU. FT Composite Carbon (4500 psig) (Rated 30 Min.) (Current)
7	68542	O-Ring (2216 psig)		807570	66 CU. FT Composite Carbon (4500 psig) (Rated 45 Min.) (Current)
	633550	O-Ring (3000 psig)		10035644	66 CU. FT. Composite Carbon (4500 psig) (Rated 45 Min.) (Current)
	630926	O-Ring (4500 psig)		807588	88 CU. FT Composite Carbon/Fiberglass (4500 psig) (Rated 60 Min.) (Current)
8	68550	Safety Plug (2216 psig)			
	495636	Safety Plug (3000 psig)			
	473254	Safety Plug (4500 psig)			
9	68543	Drill Hex Head Socket Screw (Prior Design)			
10	488858	Valve Insert Assembly			
	15339	Valve Insert Assembly			
11	14438	Valve Stem (Prior Design)			
	488859	Valve Stem (Current Design)			
12	488860	Valve Stem Washer			
13	628976	O-Ring (Current Design)			
14	488862	Packing Gland (Current Design)			
15	91728	Hand Wheel			
16	83831	Spring			
17	83731	Lock Nut			
18	94906	Protector Cap			

Cylinder Valve

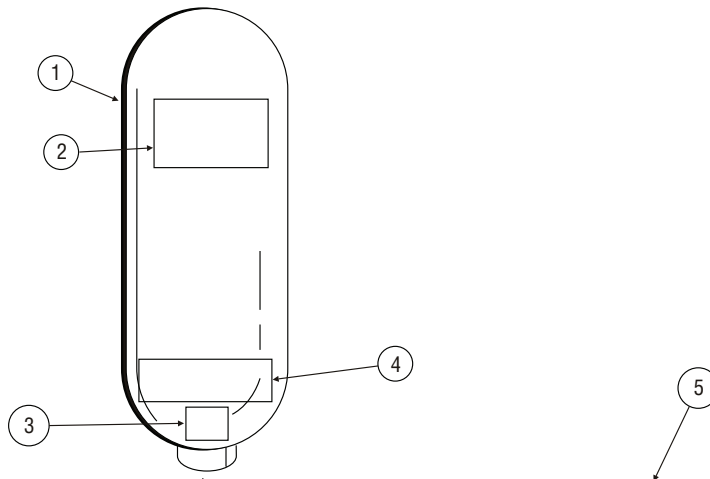

Current Design

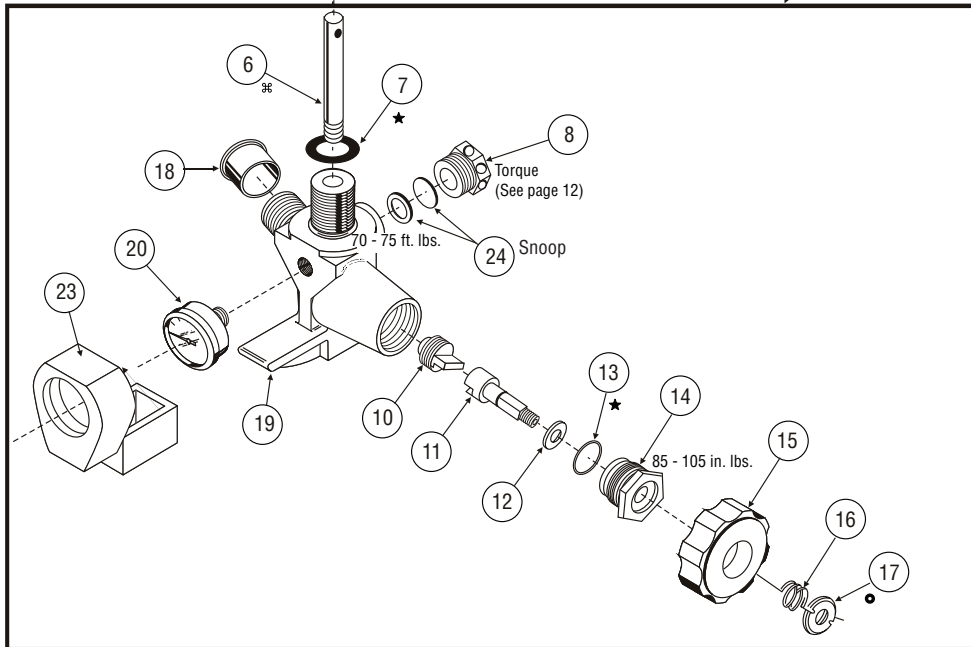

5 Prior Design

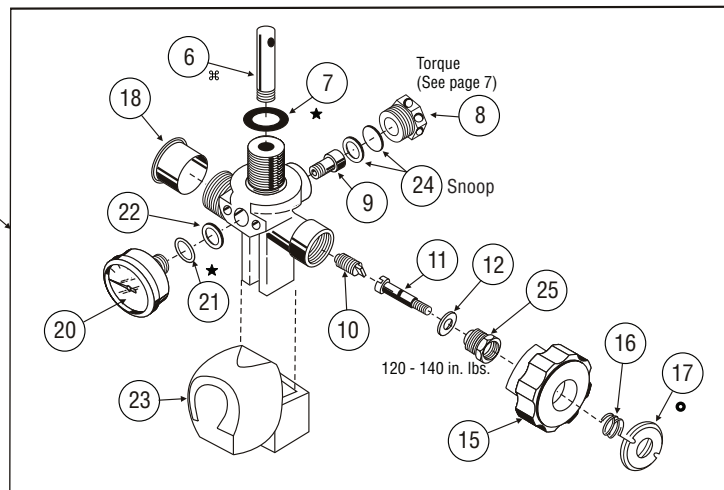

- ★ 604070 LUBRICANT
- 29787 SEALANT (LOCTITE 222)
- ⌘ 600469 SEALANT (LOCTITE 290)
- 600920 SNOOP

CYLINDER VALVE

CYLINDER BURST DISC

MSA has changed its recommended installation procedures for the cylinder valve burst disc and safety plug for current and prior designs.

Current Design:

The new installation procedure for the current design reads as follows: Place a thin film of Snoop on the new burst disc. Place the new burst disc on top of the new gasket. Be sure the gasket and disc lay flat.

Prior Design:

The new installation procedure for the prior design reads as follows: Place a thin film of Snoop on the new 4500 burst disc. Place the new burst disc on top of the new gasket. Be sure the gasket and disc lay flat.

MSA has changed its recommended procedures for torquing the cylinder valve safety plug.

The torque requirement in the chart for the custom 4500 safety plug is now 21-25 ft. lbs.

CAUTION

Certified personnel ONLY are authorized to receive this publication. This publication is an extension of the authorized maintenance procedures manual for the apparatus described, and should be kept on file with that manual.

Prior Design

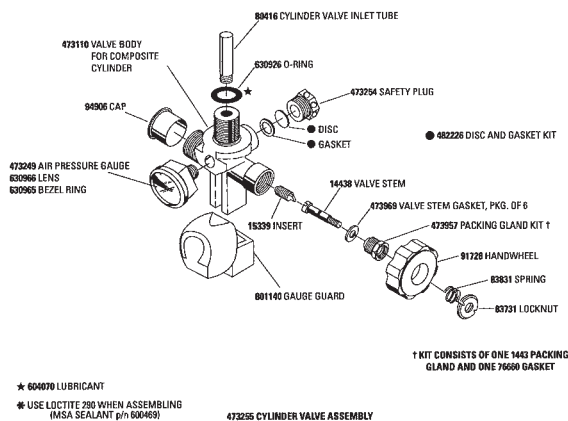

P/N 473664, 2216 psig Low Pressure and Dual-Purpose
P/N 494883, 3000 psig Low Pressure, P/N 473255
High Pressure and Dual-Purpose

WARNING

Before repairing the cylinder valve, bleed all air from the cylinder. Open the cylinder valve 1/2 turn and leave it open until all air is exhausted. Wear hearing protection if this is done in an enclosed area to avoid possible hearing damage. Do not attempt to repair the valve if the cylinder pressure gauge shows pressure. If you cannot relieve pressure by opening the cylinder valve handwheel, loosen the safety plug (no more than 1/4 turn). Failure to follow this warning can result in severe personal injury or death. This warning is for all procedures.

REMOVING AND ADJUSTING THE HANDWHEEL ASSEMBLY

1. Use wrench to remove the locknut and spring. Remove the handwheel from the top of packing gland.



2. Place a 3/4" wrench on the packing gland flats. Turn the gland counter-clockwise several turns and remove it.

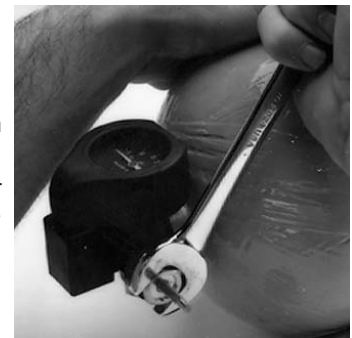

3. Replace the handwheel on the valve stem. Turn the handwheel counter-clockwise 10 turns.

Note: The procedures which follow apply only to the cylinder valves listed below. A separate set of procedures for more recently-introduced cylinder valves begins under current cylinder valve disassembly and repair.

(See the Introduction for Required Tools)
Original Cylinder Valves

CYLINDER VALVE

- Turn the valve upside-down and remove the stem, gasket, and nylon insert.

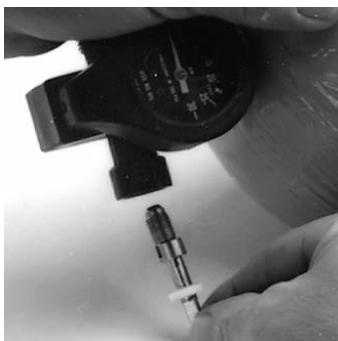

Note: If the insert shows wear, replace it.

REPLACING THE NYLON INSERT

- Install a new nylon insert into the valve body using the valve stem. Thread the stem finger-tight (clockwise).



- Place a new gasket over the valve stem and seat it on the lip in the valve body.
- Thread the packing gland into the cylinder valve body until it is finger-tight.
- Finger-loosen the valve stem counter-clockwise until the stem stops. Be sure that the packing gland does not turn.

- Use a torque wrench set at 120 to 140 in. lbs. with a 3/4" socket to tighten the packing gland.



- Place the handwheel on the stem and check the valve for proper motion. The handwheel should move freely, but with some resistance. Remove the handwheel.
- Replace the handwheel and the spring. Be sure that the valve is fully open to allow the locknut to be installed more easily. The valve stem square must fit into the square hole in the handwheel.

- Using the handwheel locknut wrench, press the locknut against the spring and tighten (clockwise).



- Open and close the valve completely several times to seat the stem, nylon insert, and the valve stem gasket. Perform a leak test to check all connections.

Note: The procedure for replacing burst discs is the same for low pressure air masks and high pressure air masks, However, wrench sizes, part numbers, and torque specifications are different (as noted).

REMOVING THE BURST DISC

- Place a socket on the safety plug hex flats and turn the plug counter-clockwise to remove the safety plug.



Note: The procedures for removing and installing burst discs are the same for all models of MSA apparatus. However, part number, tools, and torque specifications do vary. Refer to the following chart for specific items.

MSA SCBA Model	Socket Size	Safety Plug	Torque Ft/Lbs.	Burst Disc & Gasket Kit
2216 psig	11/16"	68550	50 - 53	482225
3000 psig	3/4"	495636	26 - 30	494928
4500 psig	9/16"	473254	21 - 25	482226

CYLINDER VALVE

2. Use a jeweler's screwdriver to punch a hole in the burst disc. Use retaining ring pliers to pull the disc out of the cylinder valve body. Discard the disc.



3. Use the O-ring removal tool or plastic stick to lift the gasket out of the cylinder valve body.

INSTALLING A NEW BURST DISC FOR 2216 OR 3000 PSIG

1. Insert a new gasket into the cylinder valve.



2. Place a thin film of Snoop on the new burst disc.

3. Place new burst disc on top of the gasket. Be sure that gasket and disc lay flat.

⚠ WARNING

Be sure gasket, then burst disc, are installed in the order described. Ensure threads of burst disc area and safety plug threads are free of Christo-Lube. Failure to install properly may cause burst disc malfunction, and may result in serious personal injury or death.

⚠ CAUTION

DO NOT re-use the burst disc or the gasket. You may change the burst rating.

4. Thread the safety plug into the cylinder valve body.

5. Use a torque wrench with a socket to tighten the plug.



This completes the burst disc repair procedures.

CURRENT DESIGN 4500 PSIG

Installing a New 4500 Burst Disc

1. Insert a new gasket into the cylinder valve body.

⚠ WARNING

Be sure gasket, then burst disc, are installed in the order described. Failure to install properly may cause burst disc malfunction, and may result in serious personal injury or death. Do not re-use the burst disc or the copper gasket.

2. Place a thin film of Snoop on the new 4500 Burst Disc. Place the new burst disc on top of the new gasket. Be sure the gasket and disc lay flat.

3. Thread the safety plug into the cylinder valve body. Use a torque wrench and socket to tighten the plug to the torque specified.



4. See the leak testing section. This completes the burst disc repair procedure.

CYLINDER VALVE

CYLINDER VALVE PRESSURE GAUGES

Low pressure and high pressure apparatus use an aluminum cylinder valve. The low pressure pressure gauges are secured from inside the valve body 2216 psig: P/N 473664; 3000 psig: P/N 494883. To remove the gauge, the cylinder valve must be disassembled. The high pressure pressure gauge uses a male thread which is threaded into the cylinder valve body (P/N 473255). The cylinder valve does not have to be disassembled.

Note: To remove a Low Pressure pressure gauge the burst disc must first be removed.

REMOVING THE CYLINDER VALVE GAUGE

1. Remove the rubber gauge guard. Insert a 5/32" allen wrench into the screw. Turn the wrench counter-clockwise until the screw is completely out of the cylinder valve body.



2. Pull the pressure gauge out of the cylinder valve body.



3. Use the O-ring removal tool to lift the O-ring and gland ring out of the cylinder valve body. Discard the O-ring. Be careful not to scratch the surface of the cylinder valve body.



INSTALLING A NEW LOW PRESSURE PRESSURE GAUGE

1. Install a gland ring by pressing it in place using the pressure gauge. DO NOT use a sharp tool or you may damage the gland ring.
2. Apply a thin film of Christo-Lube to the O-ring, then place the O-ring inside the gland ring and press them into place using the pressure gauge. DO NOT use a sharp tool or you may damage the O-ring.

3. Check that the two index screws on the back of the pressure gauge are tight. Insert the pressure gauge into the cylinder valve body so that the gauge needle points to the threads of the cylinder valve outlet.



4. Use a 5/32" allen wrench to insert the screw from the opposite side of the cylinder valve body. Turn the wrench clockwise to tighten the gauge.
5. Install a new burst disc, a new gasket (Burst Disc and Gasket Kit), and the safety plug.

CAUTION

DO NOT re-use the burst disc or the copper gasket. You may change the burst rating.

REMOVING THE HIGH PRESSURE PRESSURE GAUGE

1. Remove the rubber gauge protector. Unscrew and remove bezel ring and lens. Store the lens in a safe place.

2. Position the cylinder valve so that the gauge is upside-down. If the plastic center-post falls out of the gauge, apply a thin film of Christo-Lube to the part and re-install it. Place the gauge wrench on the gauge flats. Turn the gauge counter-clockwise and remove it from the cylinder valve body.



3. Clean out the threads in the cylinder valve body to be sure no tape residue remains.

CYLINDER VALVE

REASSEMBLING OR INSTALLING A NEW HIGH PRESSURE PRESSURE GAUGE (P/N 473249)

1. Apply pipe-sealing tape to gauge threads. (See Note #3).
2. Place the gauge wrench on the gauge flats. Turn the gauge clockwise to tighten. Do not over-tighten.
3. Position the gauge so that the gauge needle points to the threads of the cylinder valve outlet.
4. Replace the lens in the bezel ring and tighten the ring.
5. Replace the rubber gauge protector.
6. Refer to Leak-Testing and check all connections.

This completes the pressure gauge replacement procedure.

REMOVING THE CYLINDER VALVE BODY FROM THE CYLINDER

⚠ WARNING

Bleed all air from the cylinder. Open the cylinder valve handwheel 1/2 turn and leave it open until all air is exhausted. Wear hearing protection if this is done in an enclosed area to avoid possible hearing damage. Do not remove the valve if the cylinder pressure gauge shows pressure. If you cannot relieve pressure by opening the cylinder valve handwheel, loosen the safety plug (no more than 1/4 turn). Failure to follow this precaution may result in severe personal injury or death.

1. Secure the cylinder in a suitable fixture.
2. Pull off the rubber pressure gauge guard.

3. Place a 7/8" socket (12 point) or wrench on the flats on the top of the cylinder valve. Turn the socket counter-clockwise until the cylinder valve is completely out of the cylinder.



4. To remove the O-ring (P/N 68542 for 2216 psig valves; P/N 633550 for 3000 psig valves; P/N 630926 for 4500 psig valves), roll the O-ring over the threads.



5. If the cylinder valve inlet tube is damaged, the entire cylinder valve must be replaced. The inlet tube is "locked" with a non-removable thread sealant.

INSTALLING THE CYLINDER VALVE BODY IN THE CYLINDER

(Low Pressure 2216 psig; P/N 473664 valve body; Low Pressure 3000 psig; P/N 494883 valve body; High Pressure; P/N 473255 valve body)

1. Secure the cylinder in a suitable fixture.
2. Use a high intensity light. Inspect the inside of the cylinder for contaminants. Remove any loose particles. Be sure that the cylinder interior is completely dry.

⚠ WARNING

DO NOT use the cylinder if it has an odor or is contaminated internally. Failure to follow this precaution may result in severe personal injury or death.

3. Clean the O-ring sealing surface on the cylinder with a clean, dry, lint-free cloth. Be sure this cylinder surface is undamaged and free from contaminants, such as dirt or tape residue.

4. Inspect the cylinder neck area. Do not use the cylinder if it has scratches, cuts, or grooves which may prevent an air-tight seal.



INSTALLING A NEW INLET TUBE

(P/N 80416) in a new cylinder valve:

1. Apply one drop of Loctite 290 to the inlet threads.
2. Thread the tube into the cylinder valve and hand-tighten using pliers. Do not over-tighten.
3. Set the valve aside for 4 hours to allow the sealant to dry.
4. Apply a thin film of Christo-Lube lubricant on a new O-ring.

⚠ CAUTION

Apply Christo-Lube lubricant to the O-ring and the O-ring groove just before installing the cylinder valve. Do not store these parts after lubricating them. Christo-Lube may collect dirt and/or contaminants.

CYLINDER VALVE

5. Apply two 1/16" diameter drops of Christo-Lube in the O-ring groove at locations 180 degrees apart.

6. Place a plastic thread protector or thin piece of paper over the threads, then roll the O-ring to the bottom (male thread) end of the valve body. Rotate the O-ring 1/2 to 3/4 turn to work the Christo-Lube evenly around the groove. Remove the thread protector.



7. Insert the cylinder valve into the cylinder neck slowly and carefully so that the sealing surface of the cylinder is not damaged by the tube or sharp edge of the valve threads.



8. Use a torque wrench with a 13/16" socket to tighten the cylinder valve according to the following table:

P/N	ITEM	REQUIRED
473255	Al. Cylinder Valve for High Pressure (gray, 4500 psig)	70-75 ft. pounds
473664	Al. Cylinder Valve for Low Pressure (black, 2216 psig)	70-75 ft. pounds
494883	Al. Cylinder Valve for Low Pressure (3000 psig)	70-75 ft. pounds
93998	Brass Cyl. Valve for 2216 psig Steel Cyl., bright (silver) plated	90-100 ft. pounds
460321	Brass Cylinder Valve for Composite Cyl., 2216 psig, dull, silver, cadmium plated	45-50 ft. pounds

9. Refer to Leak-Testing and check all connections.

This completes the original cylinder valve replacement procedure.

Current Design

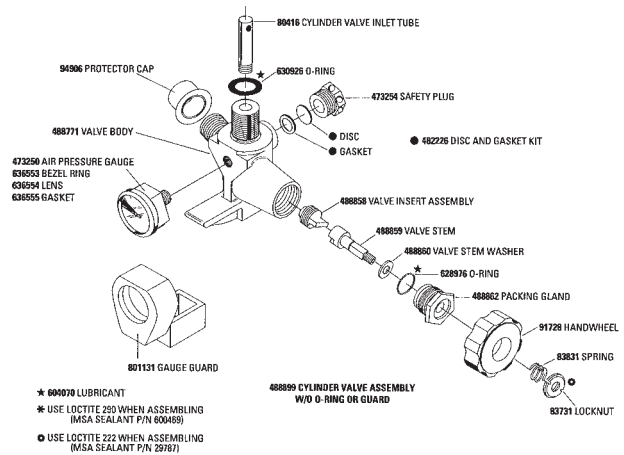

CYLINDER VALVE

CURRENT CYLINDER VALVE DISASSEMBLY AND REPAIR

⚠ WARNING

Before repairing the cylinder valve, all air must be bled from the cylinder. Open the cylinder valve handwheel 1/2 turn and leave it open until all air has been exhausted. Wear hearing protection if this is done in an enclosed area to avoid possible hearing damage. Do not attempt to repair the valve is pressure is shown on the cylinder pressure gauge. If pressure cannot be relieved by opening the cylinder valve handwheel, loosen the safety plug (no more than 1/2 turn). Failure to follow this precaution may result in serious personal injury or death.

REMOVING THE PRESSURE GAUGE

1. Remove the rubber gauge protector. Unscrew and remove bezel ring and lens. Store the lens in a safe place.
2. Position the cylinder valve so that the gauge is upside-down. If the plastic center-post falls out of the gauge, apply a thin film of Christo-Lube to the part and re-install it. Place the gauge wrench on the gauge flats. Turn the gauge counter-clockwise and remove it from the cylinder valve body.
3. Clean out the threads in the cylinder valve body to be sure no tape residue remains.

REASSEMBLING OR INSTALLING A NEW PRESSURE GAUGE

1. Apply pipe-sealing tape to gauge threads. (See Note #3).
2. Place the gauge wrench on the gauge flats. Turn the gauge clockwise to tighten. Do not over-tighten.
3. Position the gauge so that the gauge needle points to the threads of the cylinder valve outlet.
4. Replace the lens in the bezel ring and tighten the ring.
5. Replace the rubber gauge protector.
6. Refer to Leak-Testing and check all connections. This completes the pressure gauge replacement procedure.

REMOVING THE HANDWHEEL

1. Using the spanner wrench, remove the locknut and spring. Remove the handwheel from the top of the valve stem.



2. Place a 7/8" socket (deep-well) on the packing gland flats. Unscrew the packing gland from the valve body. Pull the stem out of packing gland. Remove the O-ring and valve stem washer from the packing gland.



Note: The O-ring removal tool can be used to remove O-ring from the packing gland.

3. Place the valve stem back in the valve body.



4. Replace the handwheel on the valve stem. Turn the stem until the slot drops onto the insert. Turn the handwheel counter-clockwise until the insert can be removed.



Note: If the insert shows signs of wear or damage it must be replaced.

CYLINDER VALVE

INSTALLING THE INSERT

- Using the valve stem, install the insert in the valve body. Thread the stem clockwise until the insert is fingertight.



- Place a thin film of Christo-Lube lubricant on a **new** O-ring. Place the O-ring on the packing gland.

- Place a **new** washer into the packing gland. Press the washer down to its seat.



- Insert the stem into the valve body. Turn the stem until the slot drops on the insert. Thread the packing gland into the cylinder valve until it is fingertight.



- Turn the valve stem counter-clockwise until the stem stops. Be sure the gland does not turn.
- Using the inch-pound torque wrench with a 7/8" socket (deep-well), tighten the packing gland to 85-105 in. lbs.
- The valve stem square must fit into the square hole in the handwheel. Place the handwheel on the stem and check the valve for proper motion. The handwheel should move freely.
- Replace the spring. Be sure that the valve is fully open to allow the locknut to be installed more easily.
- Put 1 drop of Loctite #222 on the stem threads.

- Using the locknut spanner wrench, press the locknut against the spring and tighten clockwise until it is flush with the top of the handwheel.



- Open and close the valve completely several times to seat the stem, insert, and the valve stem gasket.
- Leak-test the valve.

REMOVING THE BURST DISC

Note: The procedures for removing and installing burst discs are the same for all models of MSA apparatus. However, part number, tools, and torque specifications do vary. Refer to the following chart for specific items.

MSA SCBA Model	Socket Size	Safety Plug	Torque Ft/Lbs.	Burst Disc & Gasket Kit
2216 psig	11/16"	68550	50 - 53	482225
3000 psig	3/4"	495636	26 - 30	494928
4500 psig	9/16"	473254	21 - 25	482226

- Place a socket on the safety plug hex flats and turn the plug counter-clockwise to remove the safety plug.



- Use a smaller screwdriver to punch a hole in the burst disc. Pull the burst disc out of the cylinder valve body. Discard the disc.

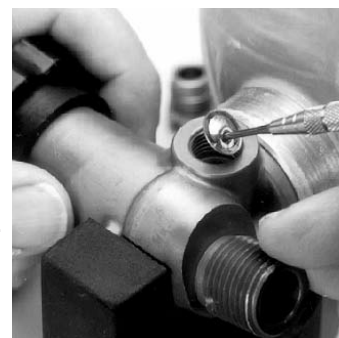

CYLINDER VALVE

3. Use the O-ring removal tool or small flat blade screwdriver to lift the gasket out of the cylinder valve body. Be careful not to scratch the surface of the cylinder valve body.

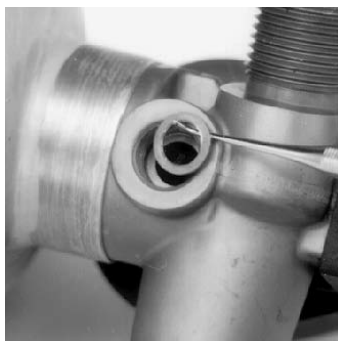

INSTALLING A NEW BURST DISC FOR 2216 OR 3000 PSIG

1. Insert a new gasket into the cylinder valve body.
2. Place a thin film of Snoop on the new burst disc. Place the new burst disc on top of the gasket. Be sure the gasket and disc lay flat.

⚠ WARNING

Be sure gasket, then burst disc, are installed in the order described. Ensure threads of burst disc area and safety plug threads are free of Christo-Lube. Failure to install properly may cause burst disc malfunction, and may result in serious personal injury or death.

⚠ CAUTION

Do not reuse the burst disc or the gasket.

3. Thread the safety plug into the cylinder valve body. Use a torque wrench and socket to tighten the plug to the torque in chart.



4. Leak-test the assembly. This completes the burst disc repair procedure.

CURRENT DESIGN 4500 PSIG

Installing a New 4500 Burst Disc

1. Insert a new gasket into the cylinder valve body.

⚠ WARNING

Be sure gasket, then burst disc, are installed in the order described. Failure to install properly may cause burst disc malfunction, and may result in serious personal injury or death.

⚠ CAUTION

Do not re-use the burst disc or the copper gasket.

2. Place a thin film of Snoop on the new 4500 Burst Disc. Place the new Burst Disc on top of the new gasket. Be sure the gasket and disc lay flat.



3. Thread the safety plug into the cylinder valve body. Use a torque wrench and socket to tighten the plug to the torque in chart.

4. See Leak-testing. This completes the burst disc repair procedure.

REPLACING THE CYLINDER VALVE BODY

1. To remove the cylinder valve body from the cylinder:
 - a. Secure the cylinder in a suitable fixture.
 - b. Remove the rubber pressure gauge guard.

- c. Place a 13/16" crowsfoot wrench on the flats on the end of the cylinder valve. Turn the valve counter-clockwise until the cylinder valve is completely out of the cylinder.



CYLINDER VALVE

- d. Roll the O-ring (P/N 68542 for 2216 psig valves; P/N 633550 for 3000 psig valves; or P/N 630926 for 4500 psig valves) over the threads.



- e. If the cylinder valve inlet tube is damaged it must be removed using a wrench or pliers.

INSTALLING A NEW INLET TUBE

1. Turn the cylinder valve upside down.
2. Place one drop of Loctite 290 on the inlet tube threads.
3. Finger-tighten the inlet tube into the valve body.



4. Allow the sealant to cure for 4 hours.

INSPECTING INSIDE OF CYLINDER

1. Use a high intensity light to inspect the inside of the cylinder for contamination. Be sure the cylinder interior is completely dry.

CAUTION

Do not use the cylinder if it has an odor, is contaminated internally, or has any visible signs of damage. Remove from service.

INSTALLING CYLINDER VALVE

1. Clean the O-ring sealing surface on the cylinder with a clean, dry, lint-free cloth. Be sure the cylinder sealing surface is undamaged and free from contaminants, such as dirt or tape residue.
2. Inspect the cylinder neck area. Do not use the cylinder if it has scratches, cuts, or grooves which may prevent an air-tight seal.
3. Install a new O-ring on the cylinder valve following the steps below:

CAUTION

Apply Christo-Lube lubricant to the O-ring and the O-ring groove just before installing the cylinder valve. Do not store these parts after lubricating them. Christo-Lube may collect dirt and/or contaminants.

- a. Place a thin film of Christo-Lube lubricant on the new O-ring.
- b. Place two small diameter drops of Christo-Lube into the O-ring groove at locations 180 degrees apart.

- c. Place a plastic thread protector or thin piece of paper over the threads, then roll the O-ring to the bottom (male thread) end of the valve body. Remove the thread protector.

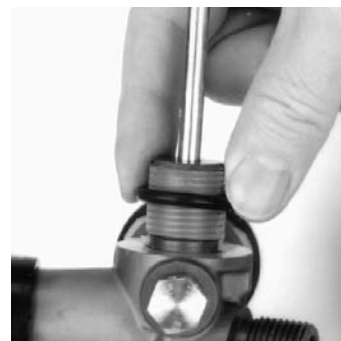

4. Carefully insert the cylinder valve into the cylinder neck so that the sealing surface of the cylinder is not damaged by the tube or sharp edges of the valve threads.
5. Use the foot-pound torque wrench with a 13/16" crowsfoot wrench to tighten the cylinder valve to 70-75 ft. lbs.
6. Leak-test the assembly. This completes the cylinder replacement procedure.