

## **Owner's Manual** **DrizAir® Dehumidifier 115V (F232-A GG)**

**DRI-EAZ PRODUCTS, INC.**  
15180 Josh Wilson Road, Burlington, WA 98233  
Phone: 800-932-3030 Fax: 360-757-7950 [www.dri-eaz.com](http://www.dri-eaz.com)

The DrizAir Dehumidifier reduces humidity in enclosed structural environments by removing water vapor from the air. The DrizAir is engineered to be rugged, durable and highly portable, making it ideally suited for construction, remodels, water damage restoration, and other applications requiring temporary, high-performance dehumidification.

### **READ AND SAVE THESE INSTRUCTIONS**

#### **SAFETY INSTRUCTIONS**



**WARNING! Electric shock hazard, rotating fan, hot surface hazards. Unplug unit before opening cover for cleaning or servicing. Unit must be grounded.**

- Inspect the power cord before use. If cord is damaged, do not use. Always grasp the plug (not the cord) to unplug.
- Insert three-prong plug on power cord into a matching electrically grounded outlet. Do not use adapter. Never cut off third prong. Do not use an extension cord.
- The unit must be operated on a 115V/60 Hz circuit protected by a Ground Fault Circuit Interrupter (GFCI) device.
- Keep motor and wiring dry.
- Do not attempt to repair the unit. For Authorized Service Centers, call Dri-Eaz at 800-932-3030.

#### **BEFORE YOU BEGIN**

##### **Unpacking your unit**

Retain all packing material and boxes for possible equipment returns.

##### **Warranty registration**

Visit [warranty.drieaz.com](http://warranty.drieaz.com) to register your purchase. Registration allows us to better assist you with using, maintaining or servicing your equipment, as well as to contact you in case we have important safety information

concerning your Dri-Eaz product. If you determine service is required, have your equipment model, serial number and original proof of purchase available and call your distributor for assistance with obtaining a return material authorization (RMA).

#### **INTRODUCTION**

Dehumidifiers reduce humidity in enclosed structural environments by removing water vapor from the air. With proper use, the DrizAir can help dry carpet, carpet pad, floors, walls, building contents and more. Using dehumidifiers can also help prevent secondary damage caused by high humidity. For best results, use the DrizAir with Dri-Eaz TurboDryer® airmovers placed around the perimeter of the room to distribute heat energy and release moisture from wet surfaces into the air.

#### **How the DrizAir dehumidifier works**

Dri-Eaz refrigerant dehumidifiers operate by pulling moist air in across a very cold evaporator coil. The moisture in the air condenses on the coil. In certain conditions, the machine operates in defrost mode, warming any frost accumulated on the evaporator coil back into water. The water collects in a tray and is pumped out through a hose.

**IMPORTANT:** Before moving the unit, make sure there's no water in the pump. See how to use the PURGE function under "How to use the control pad" on page 2.

#### **POSITIONING A DEHUMIDIFIER**

For best results, operate your dehumidifiers in an enclosed area, as this creates a drying chamber. Close all doors and windows that open to the outside to maximize the unit's water removal efficiency. Also, keep traffic through the drying chamber to a minimum. Place your DrizAir dehumidifier against a wall, away from obstructions, and keep it away from anything that could block airflow into and out of the unit.

## Managing temperature rise

DrizAir dehumidifiers warm the air as they remove moisture. Optimal drying temperatures range from 68–85°F (20–29°C).

The most accurate way to monitor temperature is with a thermo-hygrometer; however, you can use an indoor/outdoor thermometer to gauge temperature. Just make sure it is located in the center of the room away from the airflow of the dehumidifier.

For more information about creating an optimum drying environment, contact Dri-Eaz at 800-932-3030.

## OPERATING YOUR DEHUMIDIFIER

### Set unit upright

Always operate the dehumidifier in an upright position. If the unit has been stored or transported in a horizontal position, set it upright (vertical) for at least 30 minutes before operating it. When the unit is placed in a horizontal, oil from the compressor flows into the refrigerant coils reducing the ability of the dehumidifier to function.

FIG. A: FRONT

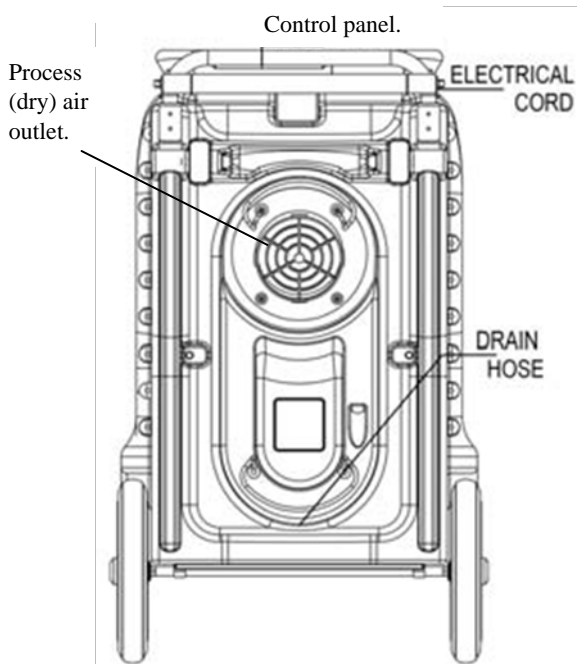

### Set up drain hose

The DrizAir condensate pump connects to a plastic drainage hose that is wrapped around the air outlet located at the back of the unit. This hose is equipped with a quick-connect fitting for quick attachment to the provided 40 ft. drain hose. Unwrap the entire hose and place the unattached end in a sink, drain, bucket or

outside – anywhere that water can drain out safely. If you use a bucket or other receptacle for water collection, check it regularly to prevent spills.

**NOTE:** Uncoil and straighten the entire drain hose. Do not leave any of part of the hose coiled on the unit and do not place the end of the hose higher than 20 ft. (6 m) above the top of the unit. Also check for kinks, or obstructions that would restrict the flow of water. Failure to do so may cause a water backup in the pump resulting in leakage.

### Plug in electrical cord

Locate the electrical cord either on the top or back of the unit. The DrizAir dehumidifier may be plugged in to a 115-volt (15 amp) grounded outlet, which is standard in most homes.

**NOTE:** If the unit experiences a loss of power, either from a power interruption or from thermal overload protection, let the unit rest for five minutes before restarting. Otherwise it might shut off again.

### Turn the unit on

Press the “on” button on the control panel.

### How to use the control panel

The control panel on DrizAir dehumidifiers has one display and four keys. The normal display messages are

DEHUMIDIFIER OFF	CMPRSR DELAY
DEHUMIDIFIER ON	PUMP PURGING
TOTAL HRS	DEFROST ON
JOB HRS	GET SERVICE ERXX



When the unit is first connected to AC power, the control panel display will cycle continuously through three messages: DEHUMIDIFIER OFF, TOTAL HOURS, and JOB HOURS.

 **ON-OFF.** Press the ON-OFF key to turn the unit on or off. When turning the machine on, usually the display reads CMPRSR DELAY and performs a numeral count down from a maximum of 60 seconds to 0. The compressor delay gives the machine time to warm up (when needed). If you don't see a compressor delay countdown, the machine is ready to go. Once the unit completes the CMPRSR DELAY, the display reads DEHUMIDIFIER ON, and continues to cycle between TOTAL HOURS, JOB HOURS and DEHUMIDIFIER ON. Press the ON-OFF key again to turn the unit off. The display will read DEHUMIDIFIER OFF.

 **DISPLAY.** Press the DISPLAY key to stop the display at DEHUMIDIFIER ON or OFF, TOTAL HOURS, or JOB HOURS as it cycles. Press DISPLAY again to re-start the display cycle.

### How to change the language display

**CAUTION:** While in the change-language mode, pressing other keys can change the programming of the machine. Do NOT press other keys you're not instructed to press.

Use the DISPLAY key to change the display language. Follow these steps:

1. Unplug the unit.
2. While holding down the DISPLAY key, plug the unit in. The display reads ENGLISH.
3. To change to FRANCAIS, DEUTSCH, or ESPANOL, press the DISPLAY key or the CLEAR key.
4. When the desired language is shown in the display, unplug the unit, and the language is set.

 **CLEAR.** Press the CLEAR key to reset the JOB HOURS

1. As the display cycles between DEHUMIDIFIER ON, JOB HOURS, and TOTAL HOURS, press the DISPLAY key when JOB HOURS appears on the screen. That will make the display read JOB HOURS steadily.
2. Then press the CLEAR key to re-set the numerals to 00000.
3. Press DISPLAY again to re-start the display cycle. NOTE: the TOTAL HOURS reading cannot be re-set.

 **PURGE.** Press the PURGE key to empty water from the pump reservoir. During normal operation, the pump purges automatically every six minutes, or whenever the reservoir is full. The display will read PUMP PURGING with a numeral countdown. To purge the pump manually:

1. Turn the power off using the OFF key, and let the unit sit plugged in for about 10 minutes. This allows water to drip from the coils and collect in the drip pan.
2. Press PURGE to remove residual water.

### Defrost mode

During normal operation, the temperature sensor detects frost forming on the coils, causing a defrost cycle to start. The display will read DEFROST ON. Dehumidification stops during the defrost cycle. When the unit completes the cycle, the display returns to DEHUMIDIFIER ON.

### Error messages

If the DrizAir's onboard diagnostics discover a problem, the unit will display "GET SERVICE," followed by "ER" and a numeral from 01 to 09. If this message appears, first follow these steps:

1. Unplug the unit and then plug it back in. This may re-set the electronics.
2. If the error message reappears, try the solution (if one is listed) in the "Error Messages," 5.
3. If the error message still appears, please contact the Dri-Eaz Service Department at 800-932-3030.

### At the end of the job

As with all dehumidifiers, once the drying job is completed, it is important to make sure the unit is completely purged of water before moving it. **To ensure that all water has drained into the pump, turn the unit off, allow it to rest for 10 minutes, then press the PURGE button.** (The unit must be plugged in for the purge to operate.) Once the purge cycle is complete, unplug the unit and remove it promptly from the job.

Before transporting, be sure to remove the external drain hose, drain it carefully, and return it to the pocket provided on the front of the unit.

## MAINTENANCE

**WARNING! ELECTRIC SHOCK HAZARD.** Unplug the DrizAir before performing any maintenance.

### Before each use

**Inspect the electrical cord for damage.** Look for fraying, cuts, etc. Do not use the unit if you find any damage. Call Dri-Eaz for the nearest Service Center at 800-932-3030.

**Inspect and vacuum filter as needed.** Keep a clean filter in the unit at all times to protect internal components from dust and other particulate build-up. The DrizAir is equipped with a 3M™ High Air-Flow filter. The HAF filter may be vacuumed clean and reused up to three times. **Do not rinse or wash the HAF filter,** as it will reduce the effectiveness of the electrostatic material.

Replace only with a new 3M HAF Filter (Dri-Eaz part no. F369). For parts and service call your local distributor or contact the Dri-Eaz Service Department at 800-932-3030.

**CAUTION:** Dust can cause the unit to overheat and shut down. Do not operate when excessive dust or airborne particles are present, such as during sanding or spray-painting. Inspect and clean air filter elements and coils frequently.

**IMPORTANT:** Replace the HAF filter whenever 1) it has been vacuumed clean 3 times or 2) it has been used on a mold remediation job or otherwise exposed to potentially dangerous contaminants.

## Monthly

**Check coils.** Dirty coils can cause the unit to overheat. Clean when visibly dirty. See Fig. B.

1. Unplug unit
2. Remove housing, locate coils and allow coils to dry if wet.
3. Vacuum both sides of the coils until clean, being careful not to let the nozzle touch the fins; as that may cause damage by bending them.

**Check catch basin tray.** Clean when dirt and debris are present.

1. Wipe clean with a rag.

## Check drain hose.

1. Look for obstructions. Disconnect and clear any debris present.
2. Reattach gravity drain hose.

## Annually

Have the pump system inspected by the Dri-Eaz Service Department (800-932-3030) or by a qualified service center.

## TRANSPORT AND STORAGE

**NOTICE:** Handle the unit carefully. Do not drop, throw, or place the unit where it could fall. Rough treatment can damage this equipment and may create a hazardous condition or void warranty.

**IMPORTANT:** Be sure to purge the water from the pump reservoir before moving the unit. See the PURGE function under "How to use the control panel" on page 2. Note that the unit must be plugged in for the Purge function to operate.

1. Do not expose the control panel to moisture, snow or rain when transporting in uncovered vehicles.
2. Store and transport securely to avoid any damaging impact to internal parts.

**FIG. B: CLEANING**

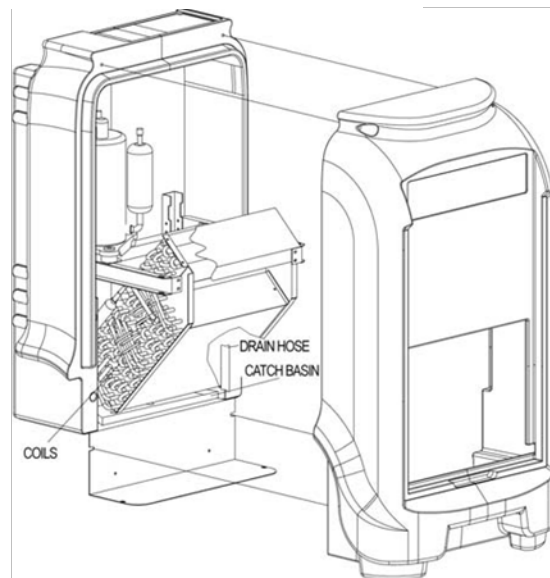

## ERROR MESSAGES

The table below shows error message that the system may detect. If the display shows an “ER” message, first unplug the unit and then plug it back in. This may re-set the electronics, and if so, no further action is required. If the error message reappears, try the solution shown under “Explanation.” If this still does not fix the problem, contact your local authorized service center or the Dri-Eaz Service Department at 800-932-3030.

ERROR MESSAGE	EXPLANATION
ER 1, 2, 3, 5, 6	Problem with electronic control panel. Contact Dri-Eaz Service.
ER 4	Check the temperature or sensor cable. Contact Dri-Eaz Service for instructions.
ER 8	Check the control panel keys. Press and release each key several times.
ER 9	Check for obstructions or kinks in the drain hose.

## TROUBLESHOOTING

FAULT	CAUSE	SOLUTION
Unit does not operate	No power to machine. Unit not switched on.	Plug in unit; check power at outlet and at base of unit. Switch unit on.
Blower wheel not turning	Obstructed blower.	Remove duct ring and grill. Remove obstruction. Replace duct ring and grill.
Unit operating, but room not dry	Not enough time to dry. Poor air movement in room. Excessive moist air infiltration.	Allow more time for drying. Increase air movement with air movers. Reduce infiltration.
Unit continuously in defrost mode	Room temperature too low	Increase room temperature.
Pump does not function	Stuck float valve	Clean float valve shaft.
Unit collects too little water	Room air is dry. Room temperature is too low.	Check humidity with hygrometer. Increase room temperature. Check filter and coils; clean as necessary.
<p><i>If the problem you are experiencing is not listed here, call your local distributor or contact the Dri-Eaz Service Department toll-free at 800-932-3030.</i></p>		

## SPECIFICATIONS

Models	DrizAir F232-A GG
Type	LGR refrigerant
Refrigerant	R-410A
Use weight	132 lbs.   60 kg
Dimensions (H x D x W)	40.5 x 22.5 x 24 in. 103 x 57 x 61 cm
Power (115V 60Hz)	8.5 amps at 80°F/60% RH 9.4 amps at 95°F/40% RH 10.6 amps 90°F/90% RH 7.4 amps at 80°F/20% RH
Water removal AHAM (80°F/60% RH)	130 pts.   61.5 liters / day
Water removal max. (90°F/90% RH)	200 pts.   88.5 liters / day
Water removal 80°F/20% RH	16 pts.   7.6 liters / day
Max process air	360 CFM   612 CMH
Operating Range	33°–100°F   1°–38°C
Air filter	3M HAF filter (part no. F368)
Power cord	25 ft.   7.6 m
Construction	Rotomolded polyethylene housing
Safety	ETL tested to UL 474 and CSA C22.2 No. 92 standards.
<i>Specifications are subject to change without notice. Some values may be approximate.</i>	

Warranty information is available at [www.dri-eaz.com](http://www.dri-eaz.com).

## CONTACT

---

Dri-Eaz Products, Inc.  
15180 Josh Wilson Rd.  
Burlington, WA 98233  
800-932-3030 [www.dri-eaz.com](http://www.dri-eaz.com)

