



5CP Plunger Pump

Standard Models

5CP5120
5CP5140

Gearbox Models

5CP5140CSSG1
5CP5150G1

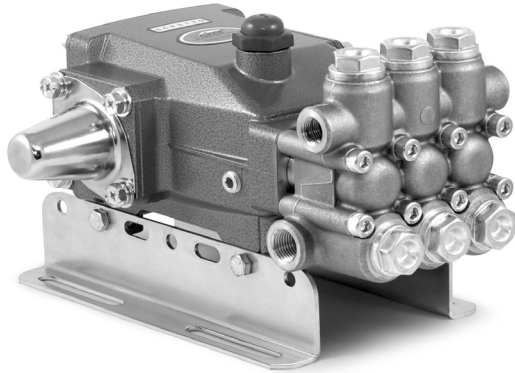

Model 5CP5120 Shown
(Rails and shaft protector sold separately)

FEATURES

- Industrial triplex design offers reliability and versatility.
- Ultra-compact footprint permits direct-drive to motor with bell housing and flexible coupling, direct-drive to engine with gearbox or belt drive for precision flow setting.
- Optional EPDM and FPM elastomers for compatibility with many liquids.
- Press-in seal cases and interchangeable valve assemblies for easy servicing.

COMMON SPECIFICATIONS

	U.S.	Metric
Inlet Pressure Range.....	-2.5 to 60 psi	(-.2 to 4 bar)
Bore	0.709"	(18mm)
Crankcase Capacity.....	17 oz.	(0.51 l)
Max. Liquid Temperature	160°F	(71°C)
Above 130°F call CAT PUMPS for inlet conditions and elastomer recommendations.		
Inlet Ports (2)	1/2" NPTF	(1/2" NPTF)
Discharge Ports (2)	3/8" NPTF	(3/8" NPTF)
Shaft Diameter	0.787"	(20 mm)
Dimensions (Pump Only).....	10.35 x 10.0 x 5.78"	(263 x 254 x 147mm)
Dimensions (w/gearbox)	10.5 x 12.4 x 6.4"	(267 x 315 x 162mm)

CAUTIONS AND WARNINGS

All High Pressure Systems require a primary pressure regulating device (i.e. regulator, unloader) and a secondary pressure relief device (i.e. pop-off valve, relief valve). Failure to install such relief devices could result in personal injury or damage to pump or property. CAT PUMPS does not assume any liability or responsibility for the operation of a customer's high pressure system.

Read all CAUTIONS and WARNINGS before commencing service or operation of any high pressure system. The CAUTIONS and WARNINGS are included in each service manual and with each Accessory Data sheet. CAUTIONS and WARNINGS can also be viewed online at www.catpumps.com/cautions-warnings or can be requested directly from CAT PUMPS.

WARRANTY

View the Limited Warranty on-line at www.catpumps.com/warranty.

SPECIFICATIONS

U.S. Metric

MODEL 5CP5120

Flow.....	5.0 gpm	(19 lpm)
Pressure Range.....	100-3000 psi	(7-210 bar)
Pump RPM	1415 rpm	(1415 rpm)
Stroke.....	0.709"	(18 mm)
Weight.....	19.9 lbs.	(9 kg)

MODEL 5CP5140

Flow.....	5.5 gpm	(21 lpm)
Pressure Range.....	100-3500 psi	(7-245 bar)
Pump RPM	1500 rpm	(1500 rpm)
Stroke.....	0.787"	(20 mm)
Weight.....	19.9 lbs.	(9 kg)

MODEL 5CP5140CSSG1

Flow.....	5.5 gpm	(21 lpm)
Pressure Range.....	100-3500 psi	(7-245 bar)
Pump RPM	1500 rpm	(1500 rpm)
Engine RPM	3060 rpm	(3060 rpm)
Stroke.....	0.787"	(20 mm)
Weight.....	26.5 lbs.	(12 kg)

MODEL 5CP5150G1

Flow.....	5.0 gpm	(19 lpm)
Pressure Range.....	100-3000 psi	(7-210 bar)
Pump RPM	1570 rpm	(1570 rpm)
Engine RPM	3200 rpm	(3200 rpm)
Stroke.....	0.650"	(16.5 mm)
Weight.....	26.5 lbs.	(12 kg)

ELECTRIC HORSEPOWER REQUIREMENTS

MODEL	FLOW		PRESSURE						MOTOR PULLEY SIZE		
			psi	psi	psi	psi	psi	psi	rpm	Pulley O.D.	
			1200	1500	2000	2500	3000	3500			
	u.s. gpm	lpm	bar 85	bar 110	bar 140	bar 175	bar 210	bar 245			
5CP5120	5.0	19	4.1	5.5	6.9	8.6	10.3	N/A	1415	6.5	
5CP5140	5.5	21	4.5	6.0	7.5	9.4	11.3	13.2	1500	6.9	
5CP5140CSSG1	5.5	21	Consult Eng. Mfg.						3060	Gearbox	
5CP5150G1	5.0	19	Consult Eng. Mfg.						N/A	3200	Gearbox

DETERMINING THE PUMP RPM	Rated gpm	=	"Desired" gpm
DETERMINING THE REQUIRED H.P.	Rated rpm	=	"Desired" rpm
DETERMINING MOTOR PULLEY SIZE	gpm x psi	=	Electric Brake
	1460	=	H. P. Required
	Motor Pulley O.D.	=	Pump Pulley O.D.
	Pump rpm	=	Motor rpm

See complete Drive Packages [Incls: Pulleys, Belts, Hubs, Key] Tech Bulletin 003. Refer to pump **Service Manual** for repair procedure and additional technical information.

PARTS LIST

ITEM	PART NUMBER		DESCRIPTION		QTY			
	5CP5140							
	5CP5120	MATL	5CP5140CSSG1	MATL	5CP5150G1	MATL		
2	30057	STL	30057	STL	30057	STL	Key (M6x6x25)	1
5	96031	STZP	96031	STZP	96031	STZP	Screw, HHC, Sems (M8x16)	8
	126542	STCPR	126542	STCPR	126542	STCPR	Screw, HHC, Sems (M8x16)	8
8	46910	AL	46910	AL	46910	AL	Cover, Bearing	2-1-0
10	14028	NBR	14028	NBR	14028	NBR	O-Ring, Bearing Cover - 70D	2-2-1
11	43222	NBR	43222	NBR	43222	NBR	Seal, Oil, Crankshaft - 70D	2-1-0
15	14480	STL	14480	STL	14480	STL	Bearing, Ball	2-2-2
20	48742	TNM	48742	TNM	48742	TNM	Rod, Connecting Assy [10/01]	3
25	46928	FCM	—	—	—	—	Crankshaft, Dual End M18 - 5120	1
	—	—	48646	FCM	—	—	Crankshaft, Dual End M20 - 5140	1
	—	—	49773	FCM	—	—	Crankshaft, Single End M 20 - 5140CSSG1	1
	—	—	—	—	48368	FCM	Crankshaft, Single End M16.5 - 5150G1	1
30	—	—	49776	AL	49776	AL	Cover, Bearing - 5140CSSG1	1
	—	—	48224	AL	48224	AL	Cover, Bearing Blind - 5140G1, 5150G1 [prior to 12/10]	1
32	46798	—	46798	—	46798	—	Cap, Oil Filler, Domed	1
33	14179	NBR	14179	NBR	14179	NBR	O-Ring, Oil Filler Cap - 70D	1
37	92241	—	92241	—	92241	—	Gauge, Oil, Bubble w/Gasket - 80D	2
38	44428	NBR	44428	NBR	44428	NBR	Gasket, Flat, Oil Gauge - 80D	2
40	92519	STZP	92519	STZP	92519	STZP	Screw, HHC, Sems (M6x16)	4
	125824	STCPR	125824	STCPR	125824	STCPR	Screw, HHC, Sems (M6x16)	4
48	25625	STCP	25625	STCP	25625	STCP	Plug, Drain (1/4"x19BSP)	1
49	23170	NBR	23170	NBR	23170	NBR	O-Ring, Drain Plug - 70D	1
50	46940	AL	46940	AL	46940	AL	Cover, Rear	1
51	14044	NBR	14044	NBR	14044	NBR	O-Ring, Rear Cover	1
53	48617	AL	48617	AL	48617	AL	Crankcase	1
64	46746	CM	46746	CM	46746	CM	Pin, Crosshead	3
65	48458	BBNP	48458	BBNP	48458	BBNP	Rod, Plunger	3
70	46838	NBR	46838	NBR	46838	NBR	Seal, Oil, Crankcase - 70D	3
75	43328	S	43328	S	43328	S	Slinger, Barrier	3
88	45697	S	45697	S	45697	S	Washer, Keyhole (M18x10)	3
90	49655	CC	49655	CC	49655	CC	Plunger (M18x50)	3
98	46730	NBR	46730	NBR	46730	NBR	Washer, Seal - 90D	3
	48394	FPM	48394	FPM	48394	FPM	Washer, Seal - 90D	3
	◆ 48432	EPDM	◆ 48432	EPDM	◆ 48432	EPDM	Washer, Seal	3
99	† 48201	SS	† 48201	SS	† 48201	SS	Retainer, Plunger w/Stud (M6)	3
100	46749	PVDF	46749	PVDF	46749	PVDF	Retainer, Seal	3
106	43243	NBR	43243	NBR	43243	NBR	Seal, LPS w/S-Spg	3
	44926	FPM	44926	FPM	44926	FPM	Seal, LPS w/SS-Spg	3
	◆ 46651	EPDM	◆ 46651	EPDM	◆ 46651	EPDM	Seal, LPS w/SS-Spg	3
	76243	ST2	76243	ST2	76243	ST2	Seal, LPS w/S-Spg	3
120	49657	BB	49657	BB	49657	BB	Case, Seal (Press-in-style)	3
121	13978	NBR	13978	NBR	13978	NBR	O-Ring, Seal Case - 70D	3
	14329	FPM	14329	FPM	14329	FPM	O-Ring, Seal Case	3
	◆ 48904	EPDM	◆ 48904	EPDM	◆ 48904	EPDM	O-Ring, Seal Case	3
127	44549	SNG	44549	SNG	44549	SNG	V-Packing	6
	45617	SFG	45617	SFG	45617	SFG	V-Packing	6
	48300	STG	48300	STG	48300	STG	V-Packing	6
128	45618	BB	45618	BB	45618	BB	Adapter, Male	3
139	22179	BBCP	22179	BBCP	22179	BBCP	Plug, Inlet (1/2"NPTM)	1
163	17547	NBR	17547	NBR	17547	NBR	O-Ring, Seat - 85D	6
	11685	FPM	11685	FPM	11685	FPM	O-Ring, Seat - 85D	6
	◆ 46648	EPDM	◆ 46648	EPDM	◆ 46648	EPDM	O-Ring, Seat - 70D	6
164	45790	S	45790	S	45790	S	Seat	6
166	46429	S	46429	S	46429	S	Valve	6
167	43750	S	43750	S	43750	S	Spring	6
168	† 44565	PVDF	† 44565	PVDF	† 44565	PVDF	Retainer, Spring	6
172	17549	NBR	17549	NBR	17549	NBR	O-Ring, Valve Plug - 70D	6
	26996	FPM	26996	FPM	26996	FPM	O-Ring, Valve Plug - 70D	6
	◆ 49133	EPDM	◆ 49133	EPDM	◆ 49133	EPDM	O-Ring, Valve Plug	6
173	48365	D	48365	D	48365	D	Back-up-Ring, Valve Plug	6
174	45900	BB	45900	BB	45900	BB	Plug, Valve	6
185	46895	FBB	46895	FBB	46895	FBB	Manifold, Head	1
188	126513	STCPR	126513	STCPR	126513	STCPR	Screw, HSH (M8x70)	8
196	22187	BBCP	22187	BBCP	22187	BBCP	Plug, Discharge (3/8"NPTM)	1
250	118672	STCP	118672	STCP	—	—	Protector, Shaft	1
255	30243	STZP	30243	STZP	30243	STZP	Mount, Direct	1
260	30611	STZP R	30611	STZP R	—	—	Mount, Rail, Assy	1
	30637	STZP	30637	STZP	—	—	Mount, Angle Assy-Retro Fit (See Tech Bulletin 078)	1
265	30659	—	30659	—	—	—	Kit, Complete Mounting	1
							(Incls: 30611, 30633, 118672) (Belt Drive Only)	
275	30944	STL	30944	STL	30944	STL	Assembly, Hub & Key (Incls: 30945, 30057)	1

EXPLODED VIEW

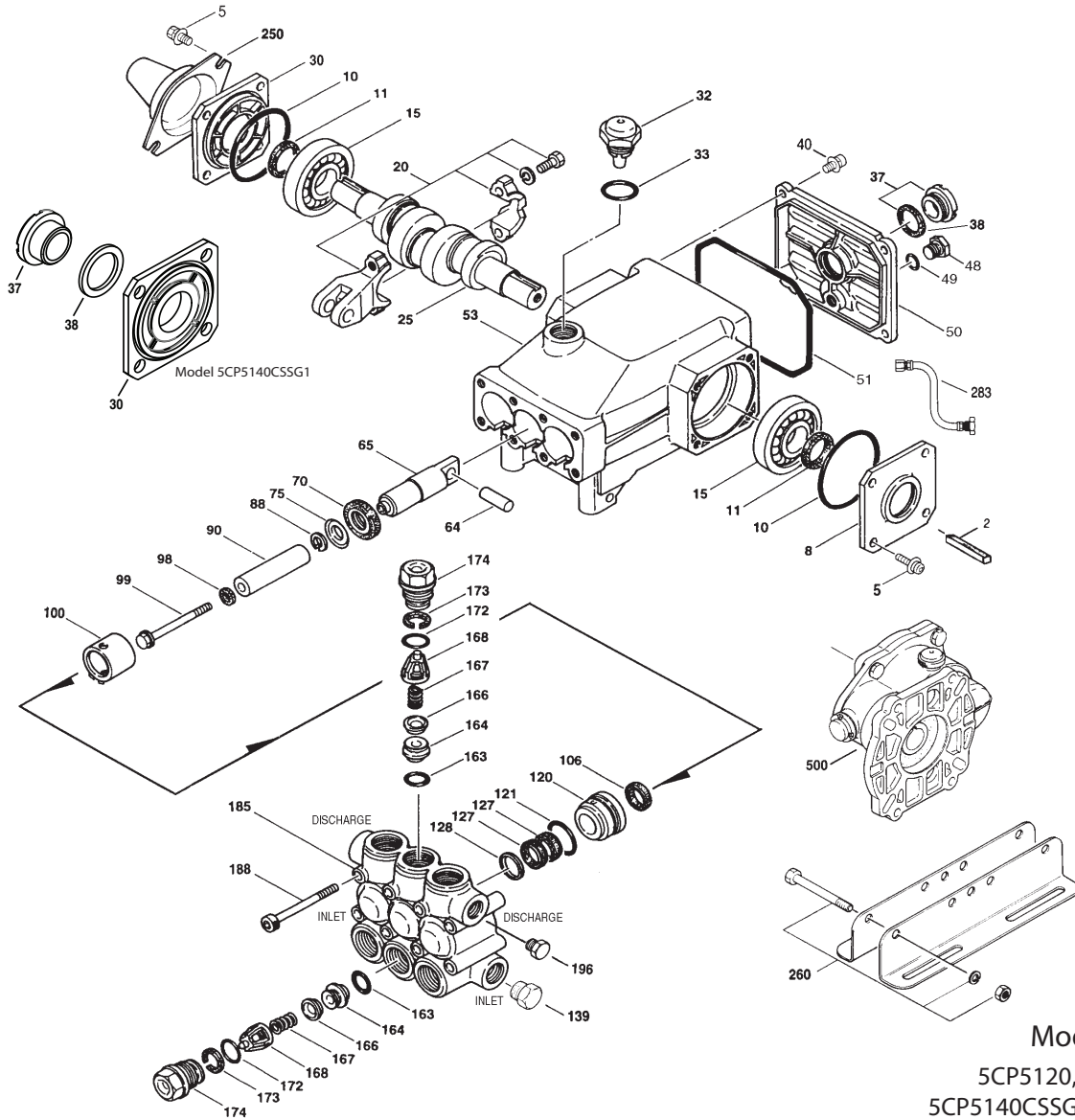

Models
5CP5120, 5CP5140
5CP5140CSSG1, 5CP5150G1
August 2011

		5CP5140					
	5CP5120	MATL	5CP5140CSSG1	MATL	5CP5150G1	MATL	
283	34334	—	34334	—	34334	— Kit, Oil Drain (3/8" x 24") (See Individual Data Sheet)	1
	76334	—	76334	—	76334	— Kit, Oil Indicator (3/8" x 24") (See Individual Data Sheet)	1
299	814844	FBB	814844	FBB	814844	FBB Head, Complete	1
300	33630	NBR	33630	NBR	33630	NBR Kit, Seal (Incls: 98,106,121,127)	1
	31350	FPM*	31350	FPM*	31350	FPM* Kit, Seal (Incls: 98,106,121,127)	1
	76645	HT	76645	HT	76645	HT Kit, Seal (Incls: 98,106,121,127)	1
	◆ 76630	EPDM	◆ 76630	EPDM	◆ 76630	EPDM Kit, Seal (Incls: 98,106,121,127)	1
	76546	STHT	76546	STHT	76546	STHT Kit, Seal (Incls: 98,106,120,121,127) Prior to 2/09	1
	76960	STHT	76960	STHT	76960	STHT Kit, Seal (Incls: 98,106,121,127) After 2/09	1
310	33060	NBR	33060	NBR	33060	NBR Kit, Valve Preassembled (Incls: 163,164,166-168,172,173)	2
	31345	FPM	31345	FPM	31345	FPM Kit, Valve Preassembled (Incls: 163,164,166-168,172,173)	2
	◆ 31735	EPDM	◆ 31735	EPDM	◆ 31735	EPDM Kit, Valve Preassembled (Incls: 163,164,166-168,172,173)	2
350	30696	STZP	30696	STZP	30696	STZP Pliers, Reverse	1
400	7850	BB	7850	BB	7850	BB Modular Unloader (See Individual Data Sheet)	1
500	—	—	8076	—	8076	— Gearbox (See Individual Data Sheet)	1
—	6107	—	6107	—	6107	— Oil, Bottle (21 oz.) ISO 68 Hydraulic (Fill to specified crankcase capacity prior to start-up)	1

Bold print part numbers are unique to a particular pump model. *Italics are optional items.* [] Date of latest production change.

◆ Silicone oil/grease required. † Production parts are different than repair parts. R Components comply with RoHS Directive.

*Review individual parts in each kit for material code identification.

View Tech Bulletins 002, 003, 024, 036, 043, 053, 060, 061, 064, 073, 074, 078 and 083 for additional information.

MATERIAL CODES (Not Part of Part Number): AL=Aluminum BB=Brass BCCP=Brass/Chrome Plated BBNP=Brass/Nickel Plated CC=Ceramic CM=Chrome-moly D=Acetal EPDM=Ethylene Propylene Diene Monomer FBB=Forged Brass FCM=Forged Chrome-moly FPM=Fluorocarbon HT=Hi-Temp (EPDM Alternative) NBR=Medium Nitrile (Buna-N) NY=Nylon PTFE=Pure Polytetrafluoroethylene PVDF=Polyvinylidene Fluoride S=304SS SS=316SS SNG=Special Blend (Buna) SFG=Special Blend (FPM) STG=Special Blend PTFE White ST2=Special Blend PTFE Grey STL=Steel STCP=Steel/Chrome Plated STZP=Steel/Zinc Plated TNM=Special High Strength

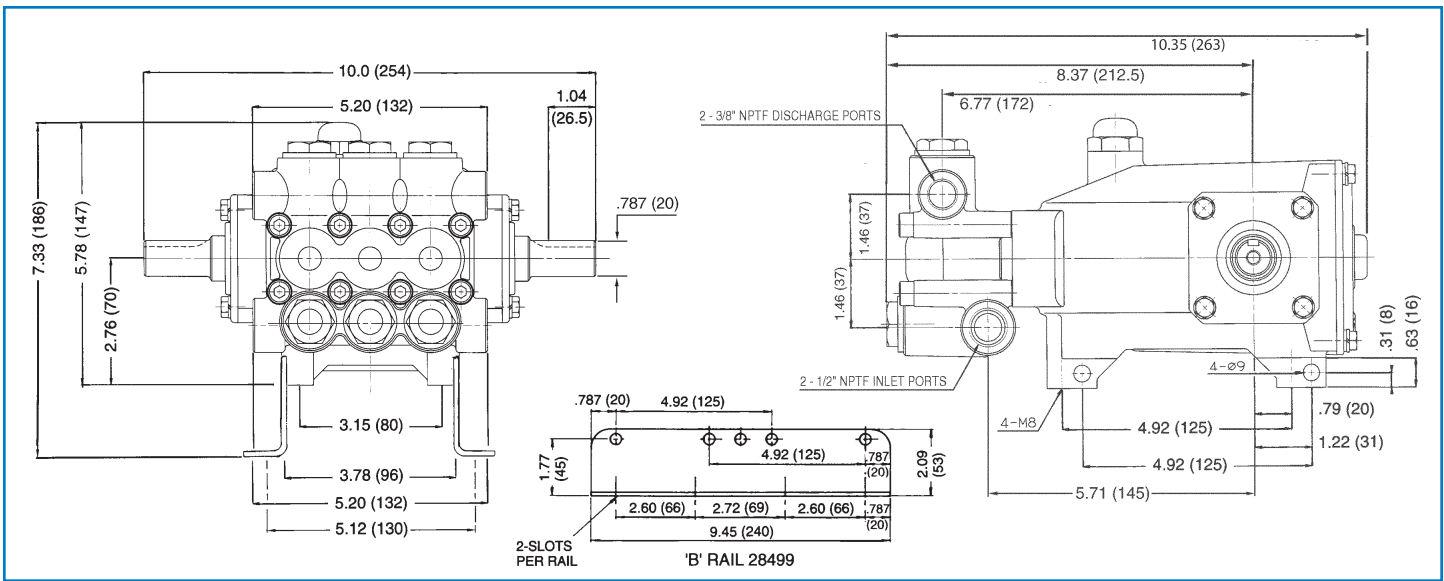

Models 5CP5120, 5CP5140

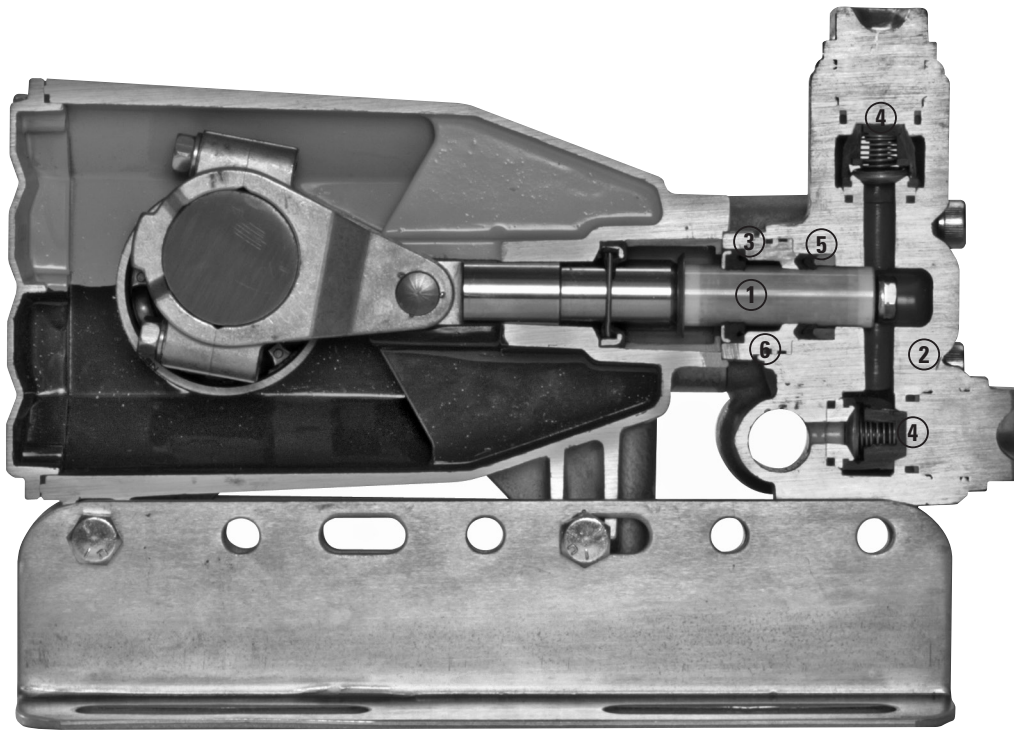

Model 5CP5120 Shown

- 1 Special concentric, high density, polished, solid ceramic **plungers** provide a true wear surface and extended seal life.
- 2 **Manifolds** are a high tensile strength forged brass for long term, continuous duty.
- 3 100% wet **seal** design adds to service life by allowing pumped liquids to cool and lubricate on both sides of the seals.
- 4 Stainless **steel valves, seats and springs** provide corrosion-resistance, ultimate seating and extended life.
- 5 Specially formulated, CAT PUMP exclusive **V-Packings** offer unmatched performance and seal life.
- 6 Press-in style **seal case** offers alignment and support for seals and “no tools” servicing.



CAT PUMPS
 1681 - 94TH LANE N.E. MINNEAPOLIS, MN 55449-4324
 PHONE (763) 780-5440 — FAX (763) 780-2958
 e-mail: techsupport@catpumps.com
 www.catpumps.com