



Pressure Sensitive Regulating Unloader

Models

7670
7672
7690

FEATURES

- Provides system pressure setting and protection for single gun (non-weep) and pump installation.
- Compact size with optional ports for easy installation.
- New ergonomic handle permits easy adjustments of pressure.
- Pressure sensitive feature permits wide range of flows and immediate pressure when gun opens.
- Color coded spring for easy identification and simple change from one model to another.
- Also functions as a secondary Relief Valve without the check valve.

⚠ WARNING

All systems require both a primary pressure regulating device (i.e., regulator, unloader) and a secondary pressure safety relief device (i.e., pop-off valve, safety valve). Failure to install such relief devices could result in personal injury or damage to the pump or to system components. CAT PUMPS does not assume any liability or responsibility for the operation of a customer's high pressure system.

SPECIFICATIONS

	U.S. Measure	Metric Measure
MODEL 7670		
Flow Range	2.5-8.0 GPM	(9.5-30 L/M)
Pressure Range	150-1450 PSI	(10-100 BAR)
Weight	1.71 lbs.	(0.78 kg)
Dimensions	7.0 x 3.12 x 2.0"	(178 x 79 x 51 mm)
MODEL 7672		
Flow Range	2.5-8.0 GPM	(9.5-30 L/M)
Pressure Range	850-3200 PSI	(60-220 BAR)
Weight	1.71 lbs.	(0.78 kg)
Dimensions	7.0 x 3.12 x 2.0"	(178 x 79 x 51 mm)
MODEL 7690		
Flow Range	2.5-8.0 GPM	(9.5-30 L/M)
Pressure Range	1000-4050 PSI	(70-280 BAR)
Weight	1.71 lbs.	(0.78 kg)
Dimensions	7.0 x 3.12 x 2.0"	(178 x 79 x 51 mm)

COMMON SPECIFICATIONS

Maximum Temperature	195°F	(90°C)
Inlet Ports (2).....	3/8" NPTF	(3/8" NPTF)
Discharge Port (1)	3/8" NPTF	(3/8" NPTF)
By-Pass Port (1).....	3/8" NPTF	(3/8" NPTF)

Unloader is stamped with a European safety pressure. Use only at above specifications to assure proper unloader life and performance.

For Relief Valve version add .100 to unloader model number.

“Customer confidence is our greatest asset”

SELECTION: This is a pressure sensitive **regulating unloader**. It is designed for systems with a **single pump**, solenoid (gate) valve, nozzle, and standard gun. **“Weep” guns are not recommended with this unloader.**

This unloader holds established system pressure in the discharge line when the trigger gun is closed or solenoid (gate) valve is closed or the nozzle is clogged, by-passing the unrequired flow. It returns to established system pressure without delay upon squeezing the trigger gun or opening the solenoid (gate) valve.

NOTE: For **multiple pump** systems, it is best to use a pressure regulator not an unloader.

Select the specific model of unloader to meet both the desired system flow (combined nozzle flow rate requirement) and the desired system pressure.

Exercise caution when matching the system requirements to the unloader flow capacity and pressure rating. Operation below the minimum flow of the unloader causes the unloader to cycle. Operation beyond the rated unloader flow causes premature valve wear, unloader cycling and prevents attaining desired system pressure.

Select a high pressure nozzle sized to provide for both the desired **system flow** and pressure and **unloader by-pass**.

CAUTION

A **MINIMUM BY-PASS FLOW** of 5% of the **UNLOADER RATED FLOW CAPACITY** is required for proper unloader performance.

When properly set this unloader protects the pump from pressure extremes associated with obstructions in the discharge line, while maintaining the established system pressure. When no flow is required by the system, the unloader by-passes all the system flow and relieves the load on the pump. Pressure is held in the discharge line (between the unloader and gun or solenoid valve) ready for a quick return to high pressure operation.

INSTALLATION: This unloader operates properly when mounted in any direction, however, it is preferred to keep the plumbing to a minimum and the adjustment handle easily accessible. The best location is directly on the pump discharge manifold head. Plumbing to and from the unloader should be at least the size of the unloader ports and flexible, high pressure hose (minimum single wire braid) is required.

This is a flow through design unloader. The standard **inlet connection** of the 7670, 7672 and 7690 is at the **back** with an alternate port on the bottom. The unloader can be mounted directly in the discharge line. The unloader should be mounted on the discharge manifold with the discharge line plumbed into the unloader discharge port.

The **by-pass connection** is on the **side** of the unloader and can be plumbed in one of the following methods. Note that prolonged by-pass can result in significant heat build-up and frequent by-pass can result in premature wear to the valve. A **MINIMUM BY-PASS OF 5%** is necessary for the unloader to operate properly.

CAUTION

If the entire output is directed through the unloader (zero by-pass) the “cushioning” feature of the by-pass liquid is eliminated and the unloader can malfunction or wear prematurely.

Check the amount of by-pass by disconnecting the by-pass line and measuring the flow into a graduated container.

By-Pass to Reservoir: Ideally the by-pass line should be directed to a reservoir with at least one baffle between the supply line to the pump (from the reservoir) and the return by-pass line (from the unloader into the reservoir). This baffle minimizes turbulence and air bubbles that could enter the pump inlet feed line. **The reservoir capacity should be 6 to 10 times the rated system flow per minute.**

By-Pass to Pump Inlet: Although not recommended, by-pass liquid can be returned to the inlet line of the pump or directly to a pump inlet port (**systems up to 10 GPM**). When using this method an *Inlet Pressure Regulator* should be installed on the inlet line to avoid excessive inlet pressure. Be certain the *Inlet Pressure Regulator* is **between** the pump inlet and the by-pass line connection. When using this method, a *Thermo Valve* should be installed in the by-pass line to protect the pump from temperature build-up and premature seal failure.

The by-pass line should be **connected to the pump inlet line at a gentle angle of 45° or less and no closer than 10 times the pump inlet port diameter** e.g. 1-1/2" port size = 15" distance from pump inlet port. **Refer to Technical Bulletin 064 for additional information on the size and length of the by-pass line.**

TYPICAL INSTALLATION

Piston Pump

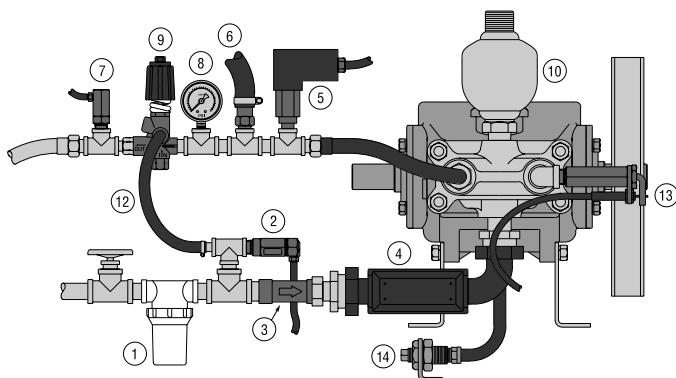

Plunger Pump

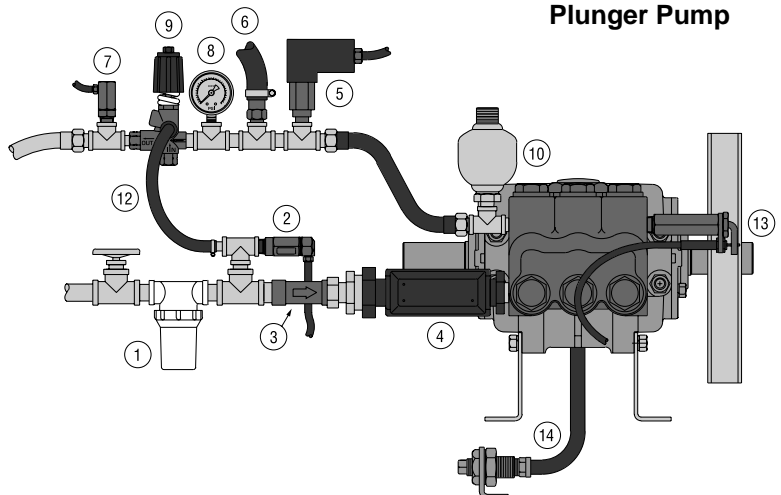

By-Pass to Drain: If the by-pass is limited and infrequent, the by-pass can easily drain to an unpressurized drain line (to the ground).

The **outlet connection** is located at the **front** of the unloader and marked with an arrow. Plumbing for the spray gun, nozzle or solenoid valve should be connected in from this discharge port.

It is recommended that a secondary protective device such as the *CAT PUMP Pop-Off Valve* be installed to assure pump protection should the unloader malfunction. Refer to Troubleshooting for more information on malfunction of unloader.

Preferred mounting of the *Prrrrr-o-lator* (pulsation dampener) is directly **on the Discharge Manifold Head**. When using an *Inlet Pressure Regulator*, mount the *Prrrrr-o-lator* **downstream from the unloader** to assure optimum performance of the regulator.

CAUTION

Oversizing the *Prrrrr-o-lator* may cause delayed response from the unloader.

PRESSURE ADJUSTMENT: Setting and adjusting the unloader must be done with the system “on”. **NOTE: The unloader is not pre-set to any specific pressure at the factory.** Set the unloader to system pressure in increments. Turn the handle clockwise, squeeze the trigger and read the pressure. If the system pressure cannot be reached by turning the handle, remove the handle assembly and spring. Keep the jam nuts on the stem. Turn the top two jam nuts clockwise a couple turns towards the bottom jam nut and replace the spring and handle. Squeeze the trigger and read the pressure again. **NOTE: Do not read the pressure at the gun or nozzle.** If further adjustment is needed to reach desired system pressure, repeat process again. When system pressure is reached, set the top locking nuts under the handle cap.

If desired system pressure cannot be reached, review TROUBLESHOOTING chart.

When servicing existing systems follow adjustment procedures as stated above for new unloaders.

NOTE: Do not adjust unloader pressure setting to compensate for a worn nozzle. Check the nozzle as part of the regular maintenance and replace as worn.

PRESSURE ADJUSTMENT AS A RELIEF VALVE: The unloader can also be used as a secondary relief valve by removing the check valve. [add .100 when ordering this version] Adjust the pressure of the relief valve in the same increments as the primary valve, then adjust the relief valve to approximately 200 PSI above the primary valve pressure setting.

Approximate Pressure Reading at Gauge	Gauge Between Pump/Unloader	Gauge Between Unloader/Gun-Nozzle-Valve
System in operation (gun open)	system pressure	system pressure
System in by-pass (gun closed)	low pressure 0-150 PSI	system pressure +200 PSI

TROUBLESHOOTING

Unloader cycles	<ul style="list-style-type: none"> Worn O-ring or check valve Fitting leaking downstream O-ring in gun worn
Liquid leaking from bottom	<ul style="list-style-type: none"> O-ring for seat or inlet fitting cut or worn
Liquid leaking from middle	<ul style="list-style-type: none"> O-ring for piston worn or cut
Unloader will not come up to pressure	<ul style="list-style-type: none"> Not properly sized for system pressure Foreign material in unloader Piston o-rings worn Nozzle worn Jam nuts not properly set
Extreme pressure spikes	<ul style="list-style-type: none"> Adjusting handle turned completely into unloader Restricted by-pass or no by-pass System flow exceeds unloader rating

WARRANTY

90 Day Warranty

Refer to complete CAT PUMPS Warranty for further information.

- | | |
|---|----------------------------------|
| 1 Inlet Filter | 8 Pressure Gauge |
| 2 Thermo Valve | 9 Pressure Regulator/Unloader |
| 3 Inlet Pressure Regulator | 10 Pulsation Dampener★ |
| 4 C. A.T. Tube
(Captive Acceleration Tube) | 11 Chemical Injector (Not Shown) |
| 5 Pressure Switch | 12 By-pass Hose |
| 6 Pop-Off Valve | 13 Throttle Controller |
| 7 Quick Start Valve | 14 Oil Drain Kit |

★ Preferred mounting of Pulsation Dampener [Prrrrr-O-Lator] is directly on the discharge manifold of the pump. The preferred mounting of the by-pass hose [when returning to the inlet] is before the Pressure Reducing Valve. If this is not possible, then mount the Prrrrr-O-Lator after the Pressure Unloading Valve to prevent pressure spikes to the pump inlet.

These illustrations show the basic elements for a typical installation of a high pressure piston or plunger pump. **Not all components shown are required for all applications or systems.** Each component presents potential problems that too often are ascribed to a perfectly functioning pump, such as: a clogged strainer, a partially closed shut-off valve, a faulty gauge, or a malfunctioning regulator/unloader. Proper system installation, routine lubrication, monitoring and maintenance of components are your basic guarantees of optimum pump performance. CAT PUMPS does not assume any liability or responsibility for the design or operation of a customer’s high pressure system.

EXPLODED VIEW

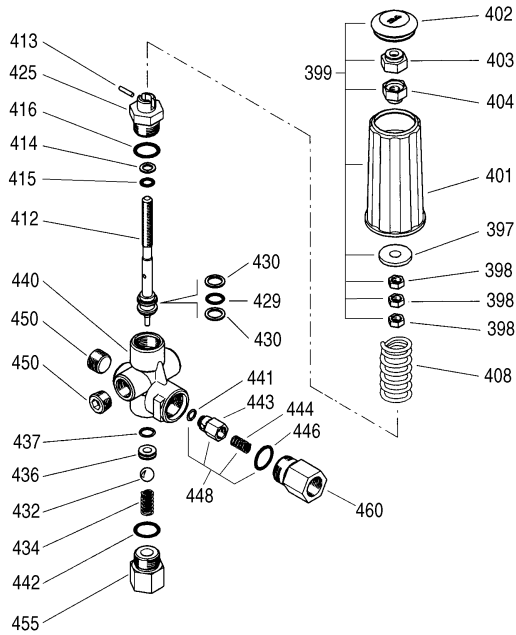

CUTAWAY

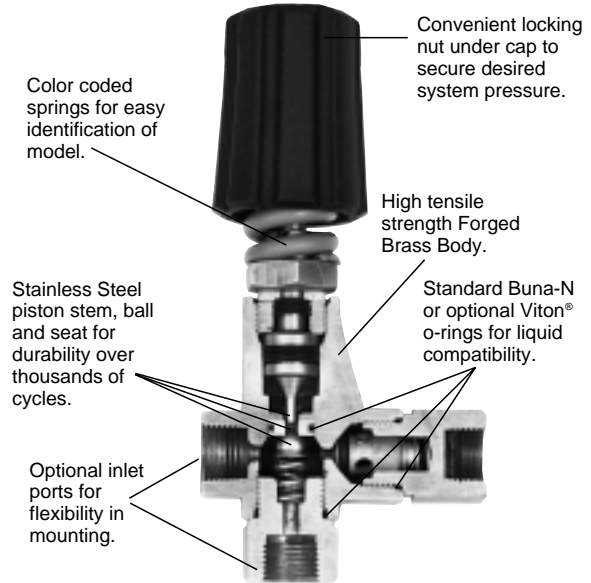

PARTS LIST

ITEM	DESCRIPTION	MODEL NUMBER						QTY
		7670	MATL	7672	MATL	7690	MATL	
397	Washer, Flat	—	STL	—	STL	—	STL	1
398	Nut, Jam (M8x1.25)	32116	BB	32116	BB	32116	BB	3
399	Assembly, Adjusting Handle (Incls: 397, 398, 401, 402, 403, 404)	31395	NY	31395	NY	31395	NY	1
401	Handle, Adjusting	31284	NY	31284	NY	31284	NY	1
402	Cap, Handle	31286	NY	31286	NY	31286	NY	1
403	Nut, Hex, NyLock (M8)	32811	STZP	32811	STZP	32811	STZP	1
404	Nut, Adjust (M8)	31287	BB	31287	BB	31287	BB	1
408	Spring, White (1450 PSI)	32090	STL	—	—	—	—	1
	Spring, Blue (3450 PSI)	—	—	32092	STL	32092	STL	1
412	Stem, Piston	33219	S	33219	S	33219	S	1
413	Pin, Piston, Lock	32818	S	32818	S	32818	S	1
414	Back-up-Ring, Piston Stem	32873	PTFE	32873	PTFE	32873	PTFE	1
415	O-Ring, Piston Stem	—	NBR/FPM	—	NBR/FPM	—	NBR/FPM	1
416	O-Ring, Retainer	—	NBR/FPM	—	NBR/FPM	—	NBR/FPM	1
425	Retainer, Piston	33318	BB	33318	BB	33318	BB	1
429	O-Ring, Piston	—	NBR/FPM	—	NBR/FPM	—	NBR/FPM	1
430	Back-up-Ring, Piston	33303	PTFE	33303	PTFE	33303	PTFE	2
432	Ball	32289	SSSS	32289	SSSS	31075	SSSS	1
434	Spring	—	SS	—	SS	—	SS	1
436	Seat, w/O-Ring	—	NBR	—	NBR	33806	NBR	1
437	O-Ring, Seat - 85D	—	NBR/FPM	—	NBR/FPM	—	NBR/FPM	1
440	Body	—	FBB	—	FBB	—	FBB	1
441	O-Ring, Check Valve	—	NBR/FPM	—	NBR/FPM	—	NBR/FPM	1
442	O-Ring, Inlet Fitting	—	NBR/FPM	—	NBR/FPM	—	NBR/FPM	1
443	Check Valve	33852	BB	33852	BB	33852	BB	1
444	Spring, Check Valve	33843	S	33843	S	33843	S	1
446	O-Ring, Discharge Fitting	—	NBR/FPM	—	NBR/FPM	—	NBR/FPM	1
448	Kit, Check Valve (Incls: 441, 443, 444, 446)	31370	NBR	31370	NBR	31371	BB	1
450	Plug, Inlet (3/8" NPTM)	46690	BB	46690	BB	46690	BB	1
455	Fitting, Inlet (3/8" NPTF)	32111	BB	32111	BB	31211	BB	1
458	Kit, Valve (Incls: 432, 434, 436, 442)	33147	NBR	33147	NBR	31147	NBR	1
460	Fitting, Discharge (3/8" NPTF)	33855	BB	33855	BB	33855	BB	1
468	Kit, O-Ring (Incls: 414, 415, 416, 429, 430, 437, 441, 442, 446)	31365	NBR	31365	NBR	31366	NBR	1
	Kit, O-Ring (Incls: 414, 415, 416, 429, 430, 437, 441, 442, 446)	31375	FPM	31375	FPM	—	FPM	1

Bold print part numbers are unique to a particular model. Italics are optional items.

MATERIAL CODES (Not Part of Part Number): BB=Brass FPM=Fluorocarbon (Viton®) NBR=Medium Nitrile (Buna-N) NY=Nylon PTFE=Pure Teflon® S=304SS SSSS=440SS STL=Steel STZP=Steel/Zinc Plated

Products described hereon are covered by one or more of the following U.S. patents 3558244, 3652188, 3809508, 3920356, 3930756 and 5035580

World Headquarters

CAT PUMPS

1681 - 94th Lane N.E. Minneapolis, MN 55449-4324

Phone (763) 780-5440 — FAX (763) 780-2958

e-mail: sales@catpumps.com

www.catpumps.com

International Inquiries

FAX (763) 785-4329

e-mail: intl@catpumps.com



"The World's Most Dependable Pumps"

CAT PUMPS (U.K.) LTD.

1 Fleet Business Park, Sandy Lane, Church Crookham, Fleet

Hampshire GU52 8BF, England

Phone Fleet 44 1252-622031 — Fax 44 1252-626655

e-mail: sales@catpumps.co.uk

N.V. CAT PUMPS INTERNATIONAL S.A.

Heiveldekens 6A, 2550 Kontich, Belgium

Phone 32-3-450.71.50 — Fax 32-3-450.71.51

e-mail: cpi@catpumps.be www.catpumps.be

CAT PUMPS DEUTSCHLAND GmbH

Buchwiese 2, D-65510 Idstein, Germany

Phone 49 6126-9303 0 — Fax 49 6126-9303 33

e-mail: catpumps@t-online.de www.catpumps.de