

Owner's Manual — Phoenix 1200 Desiccant Dehumidifier

Installation, Operation & Service Instructions

Read and Save These Instructions

The Phoenix 1200 Portable Desiccant Dehumidifier offers the finest in air-drying equipment; however, this machine can only provide maximum service if properly installed, operated, and maintained.

This manual is provided to acquaint you with the dehumidifier so that installation, operation and maintenance can proceed successfully. Ultimate satisfaction depends on the quality of installation and a thorough understanding of this equipment. The dehumidifier is built around tested engineering principles and has passed a thorough inspection for quality of workmanship and function.



PN 4028000

The Phoenix 1200 Desiccant Dehumidifier

- 900 CFM process airflow
- 300 CFM reactivation airflow
- 12" Inlet
- 8" Reactivation Outlet
- Dual 8" Process Outlets
- 230 Volt single phase:
 - User selectable 25 or 40 amp draw
 - All the standard 120 volt outlets available for Phoenix air movers
- Fits easily through doors, up truck ramps and in SUVs
- Quiet operation
 - Constant run mode or humidistat controlled mode
- Hi-Lo handles for easy lifting
- External filters and fuses for simple maintenance
- Tough weather resistant design
- Operating Range -10°F to 120°F

Specifications subject to change without notice.

TS-449b

06/10

Table of Contents

Introduction	1
1. Specifications	2
2. Operation	2
3. Installation Instructions	3
3.1 Inspection	3
3.2 Placing The Machine	3
3.3 Electrical	3
3.4 Duct Work	3
4. Operating Instructions	3
4.1 Airflow	3
4.2 Desiccant Wheel Rotation	3
5. Start-Up	3
5.1 Manual Operation	3
5.2 Automatic Operation	3
5.3 Make-Up Air Vent	4
6. Controls	4
6.1 Control Switch	4
6.2 High/Low Switch	4
6.3 Unit Run Light	4
6.4 Humidistat	4
6.5 Electric Reactivation Controls	4
7. Dehumidifier Maintenance Instructions	4
7.1 General Maintenance	4
7.2 Cabinet	4
7.3 Filter	4
7.4 Fan and Motor	4
8. Drive Motor	5
8.1 Rotor Drive Belt	5
8.2 Seals	5
8.3 Desiccant Media	5
9. Dehumidifier Service Instructions	5
9.1 Removing Desiccant Rotor	5
9.2 Changing Seals	5
9.3 Installing Seals	5
9.4 Troubleshooting	6
10. Service Parts	7
11. Wiring Diagram	8
Warranty	9

Serial No. _____

Purchase Date _____/_____/_____

Dealer's Name _____

Read the operation and maintenance instructions carefully before using this unit. Proper adherence to these instructions is essential to obtain maximum benefit from your Phoenix 1200 dehumidifier.

WARNING

- It is designed to be used **INDOORS ONLY**.
- If used in a wet area, plug it into a **GROUND FAULT INTERRUPTER**.
- **DO NOT** use the Phoenix 1200 as a bench or table.
- It must always be used in the upright position.

1 Specifications

Part No.	4028000
Power	230 volt single phase unit with user selectable 25 or 40 amp draw
Water Removal	344 pints/day (43 Gallons) @ AHAM (80°F, 60%)
Blower	900 CFM Process Airflow 300 CFM React Airflow
Operating Range	-10°F to 140°F
Duct Options	Process/React Inlet: 12" flex duct (optional) Process Outlet: 8" flex duct or layflat x 2 Reactivation Outlet: 8" flex duct (required)
Warranty	1 year Parts and Service

Dimensions

	Machine
Width	26.5"
Height	35"
Depth	45"
Weight	265 lbs

Popular Accessories And Replacement Parts

4020550	24" x 12" x 2" Pleated Media MERV-7
4024750	12" x 25' Flex Duct
4024935	10" x 250' Lay-flat Duct
4024440	Kestrel 3000 Multi-Meter

2 Operation

The function of the dehumidifier is to remove moisture (in the vapor state) from an air stream. This is accomplished by exposing the air to an adsorbing media (desiccant) in a sealed air stream (process). After the desiccant has adsorbed moisture, it is exposed to a second air stream at an elevated temperature (reactivation). This causes the moisture to be driven out of the desiccant preparing it for more moisture adsorption. This process is done on a continuous basis, providing a constant drying process.

The two air streams (process and reactivation) are separated by seals, which contact the desiccant media. Figure "A" illustrates the relationship of the seals and airflow pattern.

The dehumidifier is designed with the two air streams flowing in opposite directions (counter flow) thereby maximizing the energy efficiency of the equipment.

Principle of Operation

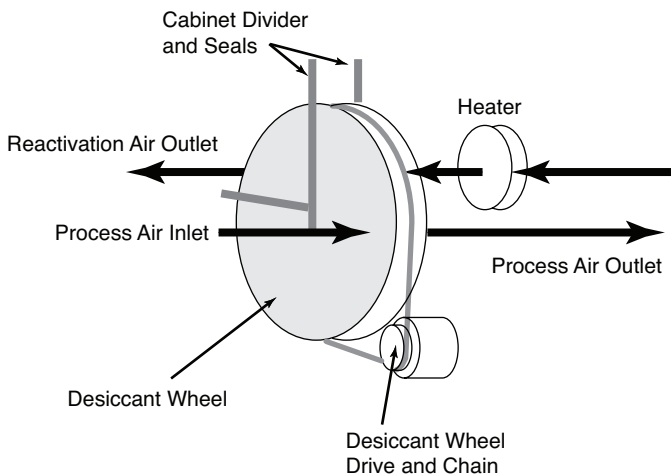

3 Installation Instructions

Proper installation of this dehumidifier is very important for maximum service and performance. Refer to “Installation Instructions for the Phoenix 1200 Dehumidifier” label on top of machine above control panel.

3.1 Inspection

Thoroughly inspect the dehumidifier inside and out to insure that no damage has occurred during shipping. (If any damage is found, a claim should be made to the shipping company immediately).

3.2 Placing The Machine

Remove any external packaging or crating.

Note: *The supplied casters are stored in the process outlet plenum for shipping. Remove and install casters prior to operating machine. The dehumidifier should be carefully set in place before connecting hose ducts.*

3.3 Electrical

All local and state codes must be strictly adhered to and good electrical practices should be followed to achieve the best installation possible. The supplied power cord must have a proper plug or connection as required. Overload protection should be sized for 40 amps @220/1/60.

(See Electrical Schematic drawing in the back of this manual for internal wiring).

The power supply should be checked to be certain that the supply voltage agrees with the equipment nameplate. Serious damage to motors and controls can occur if incorrect voltage is applied.

3.4 Duct Work

The duct work requirements for these systems are much more critical than conventional air conditioning systems. ALL SUPPLY AND RETURN AIR DUCT HOSES FOR THE DEHUMIDIFIER MUST BE AIR AND VAPOR TIGHT. This is extremely important for proper dehumidifier performance. Even though the dehumidifier is removing moisture, it may not perform properly if moisture enters the dry air stream through leaks in the ductwork. The air ducts must be properly sized to keep pressure losses at a minimum, and prevent this loss from exceeding the designed fan static capability. It is important to insure that the reactivation discharge air does not enter the process or reactivation inlets. See “Specifications” drawing for fan external static pressure.

4 Operating Instructions

Refer to “Installation Instructions for Phoenix 1200 Dehumidifier” label on top of machine above control panel.

The Phoenix 1200 dehumidifier comes complete ready for operation. All that is required is to provide the proper power source and duct connections.

4.1 Airflow

The dehumidifier uses two distinct air streams. This eliminates the requirement to “balance” the air streams.

4.2 Desiccant Wheel Rotation

A fixed speed gear motor, timing pulley, and timing belt rotate the desiccant rotor at the proper speed. The belt tension is maintained with a spring loaded roller type tensioner.

5 Start-Up

At this point it is assumed that the installation is complete and that the recommendations and instructions have been followed. The following will outline the proper procedures for starting and adjusting the dehumidifier.

5.1 Manual Operation

If the dehumidifier is to be run continuously, without the use of the installed automatic humidistat, place the “HAND/OFF/AUTO” switch into the “HAND” position. The unit will energize, as indicated by the green “UNIT RUN” light, and commence dehumidification.

5.2 Automatic Operation

If the dehumidifier is to be operated by the installed humidistat, adjust the humidistat to the desired set point, and place the “HAND/OFF/AUTO” switch into the “AUTO” position. Provided that sensed relative humidity requires dehumidifier operation, the unit will energize, as indicated by the green “UNIT RUN” light, and commence dehumidification.

5.3 Make-Up Air Vent

A make-up air vent is located under a hood at the top of the inlet filter box. When used in the space to be conditioned, the vent should be fully closed. If the dehumidifier is placed outside the conditioned space, the vent should be fully opened to allow for make-up air into the inlet.

6 Controls

6.1 Control Switch (CS)

The control switch “CS” is a three-position switch equipped with “HAND/OFF/AUTO” positions. In the “HAND” position, the unit will run continuously. In the “AUTO” position the unit will cycle on and off based on the installed humidistat, or if connected, an external control. In the “OFF” position, the unit is off.

6.2 High/Low Switch

The high/low switch is a two position switch which allows part of the reactivation heaters to be switched off when insufficient power is available for all to operate. Normal operation is with the switch in the “HIGH” position.

“HIGH” position full load: 40a @ 220/1/60.

“LOW” position full load: 25a @ 220/1/60.

6.3 Unit Run Light

The dehumidifier is equipped with a green “UNIT RUN” light. This light will be energized whenever the unit control contactor has been “pulled in” to energize the unit. The green “UNIT RUN” light will not be energized when the unit is in the “OFF” position, or in the “AUTO” position if the installed humidistat or external control device is not energizing the unit.

6.4 Humidistat

The dehumidifier is equipped with an internal humidistat installed in the Process Inlet. The humidistat should be adjusted (by rotating the knob) for the desired space humidity level. The humidistat is a standard quality mylar type device, accurate to within + 5% of set point. For external control, the installed humidistat may be disconnected per the wiring diagram, and the unit subsequently connected to an external control device. As with any electrical work, the unit should be de-energized and locked out prior to the start of such work. Additionally, check external control device specifications for compatibility with the dehumidifier.

6.5 Electric Reactivation Controls

The dehumidifier is equipped with Positive Temperature Coefficient (PTC) electric reactivation heaters. These heaters are self-regulating and require no over temperature safety devices or other electrical controls.

7 Dehumidifier Maintenance Instructions

7.1 General Maintenance

A definitive time schedule should be established for inspecting all rotating parts and components. Inspection requirements depend on the frequency of operation, transport, and operating conditions. Periodically check the condition of the air filter, rotating parts, and fasteners to ensure they are secure and in proper working order. Periodically check airflow to make sure there are no obstructions to airflow in outlet or inlet ductwork.

Recommended minimum inspections:

- Upon installation
- After 1 week of operation.
- After 3 months.
- Annually thereafter or upon loss of performance.

7.2 Cabinet

Side access panels are attached via \odot turn cam latch type fasteners. Rotate fully counterclockwise with a 1/8” hex driver to release latches. Pull panels straight out to remove.

CAUTION

CAUTION: Disconnect power before removing access panels. The condition of the cabinet gaskets should be observed during inspection and servicing to insure a good seal. Any leaks must be sealed and panels securely fastened for proper dehumidifier operation.

7.3 Filter

The maintenance interval for the filter depends directly on the cleanliness of the air entering the dehumidifier. It is suggested that a program be established to assure that the filters are replaced or cleaned prior to becoming clogged to the point they create a system problem. The standard filters supplied are of a disposable cartridge type media. A minimum 30% ASHRAE standard filter must be used to protect the desiccant media.

7.4 Fan and Motor

Fan and motor bearings are permanently lubricated and do not require maintenance.

Fan wheel - inspect wheel blades for accumulation of dust and dirt. Clean thoroughly with compressed air and or vacuum. The wheel should not strike the housing or the inlet ring. Make sure wheel is rotating in the proper direction.

Fan belt and pulleys - Check fan belt condition and tension to ensure it does not slip on pulleys.

Do Not Over Tighten as bearing damage can occur. If the belt shows signs of excessive wear or damage, replace as necessary. Check to ensure pulleys are secure.

8 Drive Motor

The media drive motor is permanently lubricated and requires no maintenance.

8.1 Rotor Drive Belt

A spring loaded tensioner keeps the belt sufficiently tensioned. Check the belt for signs of excessive wear. Replace as necessary. If additional tension is required, simply move the tension spring to a more extended hole as required.

8.2 Seals

All of the high temperature seals which separate the process and reactivation compartments, are manufactured specifically for Air Quest Systems. Normally, the seals will not require service or replacement. However, should damage occur, or if poor performance as the result of an air leak is suspected, the following inspection must be performed to determine whether the seals should be replaced:

Inspection:

1. Turn the unit off and remove the access covers.
2. Visually inspect for gaps between the desiccant media and the seals.
3. If significant gaps, wear, or damage are observed, the seal needs to be replaced.

8.3 Desiccant Media

The silica gel desiccant media supplied with the dehumidifier will last indefinitely under ideal conditions. Due to the nature of desiccants they make very good filters. The life of the desiccant is directly related to the airborne contaminants passed through it. Atmospheric contaminants, exposure to acidic gases/or air streams, and contact with petroleum based airborne particles can reduce the efficiency of the desiccant media. Although the desiccant media is considered a cleanable/washable media, the preferred method of cleaning is to blow dust out with compressed air. Washing the media is not recommended as wash water impurities may contaminate the desiccant. Proper filtration and preventing contact with chemicals will greatly improve the life of the desiccant. Inspect the face of the media to see that no surface damage has occurred. If damage is noticed, please contact Air Quest Systems for assistance. The rotor should turn smoothly upon the shaft, if not check the support bearings.

9 Dehumidifier Service Instructions

9.1 Removing Desiccant Rotor

Desiccant rotor removal is accomplished as follows:

1. Shut off all power.
2. Remove side access covers.
3. Push tensioner to loosen belt and remove from drive pulley. Allow belt to hang from the rotor.

Remove drive motor pulley, drive motor, and tensioner.

Note: The rotor may be removed from the reactivation side to eliminate the need to remove the drive components.

4. Support rotor as necessary with a block of wood or similar device. Remove the cap screws securing the rotor center shaft.
5. Pull on drive belt to slide media slightly toward the front (process side) of the unit. Remove the rotor shaft and shaft washers.
6. Remove the rotor from the cabinet by pulling on the drive belt.

To re-install media, reverse the above procedure.

NOTE: Drive belt must be around perimeter of media before re-installing! Make sure the seal does not roll off of the divider during media installation. Carefully push perimeter seals into place (roll out on rotor panels) with a putty knife or similar tool. Be careful not to cut or damage seal. This can be assisted by rotating the rotor as the seal is smoothed into place.

9.2 Changing Seals

1. Follow procedure for removing media.
2. Remove the clamp ring holding the seal in place by loosening one of the clamp screws.
3. Remove seal from media.
4. Repeat above steps for opposite side.

9.3 Installing Seals

1. Replacement seals as shipped from the factory require field fitting (cutting to length).
2. Dry fit the seal to perimeter and divider panel length. Cut replacement seals to length of original seals.
3. Ensure that the cassette face panels are clean.
4. Apply the perimeter seal around wheel. Approximately 1/2" of seal will extend past the face of the rotor. Install clamp and loosely tighten. Adjust seal and clamp position as required and tighten clamp screws. Repeat this procedure for the opposite face. (Ref. Figure A).

Note: The direction of the perimeter seal should be so the outside overlap is pointing in the direction of rotation. (If you have questions, contact Phoenix.)

5. Remove the old divider seal. Install new divider seal using original metal screws and seals retainers. (Ref Figure B).

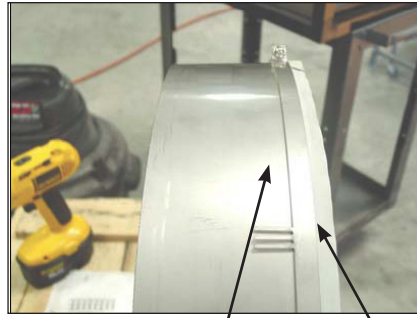

Figure A

Seal Clamp

Perimeter Seal

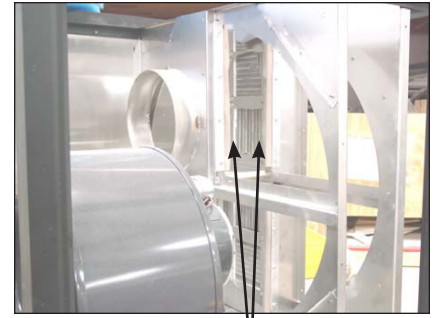

Figure B

Divider Seals

9.4 Troubleshooting

Troubleshooting Guide			
Trouble	Probable Fault	Probable Cause	Corrective Action
Unit stopped (Fan off No Heater)	Power and control failure	1. Main power off	Check line and main power supply
		2. Control power off <ul style="list-style-type: none"> a. Control circuit fuse blown b. Faulty control transformer c. Control switch open d. Humidistat satisfied e. Faulty control elements 	<ul style="list-style-type: none"> a. Replace fuse b. Replace transformer c. Close or replace switch d. Turn down to lower setpoint e. Check and repair or replace as req'd
Fan off (heater functions)	Power or mechanical failure	1. Blown motor fuse	Replace control circuit fuse
		2. Bad Contactor	Repair or replace
		3. Burned out motor	Repair or replace
		4. Failures of fan motor	Repair or replace as req'd
Unit running but humidity rises	Excessive infiltration of humid air into the controlled space	1. Excessive unconditioned make-up air	Reduce make-up air
		2. Leaking ducts and/or air handling equip. outside controlled space	Seal leaks
		3. Access openings to space not sealed	Close and/or seal
		4. Space not vapor tight	Seal with paint and/or vapor barrier
	Faulty humidity controls	1. Humidistat <ul style="list-style-type: none"> a. Improper adjustment b. Defective 	<ul style="list-style-type: none"> a. Readjust b. Replace
		Inadequate air flow	1. Excessive static pressure loss <ul style="list-style-type: none"> a. Dirty filter b. Obstruction at inlet, outlet or ducting c. Clogged desiccant media (High pressure drop across media)
	Inadequate or no reactivation heat	1. Element burnout	Replace.
		2. Low voltage	Correct power supply
		3. Faulty control elements	Check, repair, or replace
	Air seals and gaskets	1. Air leakage into dehumidifier	Replace panel gaskets and seals
		2. Air bypassing media or leaking seals	Check media position, replace seals
	Ineffective desiccant media	1. Media drive failure <ul style="list-style-type: none"> a. Belt b. Motor 	<ul style="list-style-type: none"> a. Repair or replace b. Repair or replace
		2. Damaged desiccant media	Repair or replace
		3. Contaminated desiccant	Clean or replace rotor

10 Service Parts

Description	Qty	Part Number
Disconnect Switch	1	4028301
Control Switch	1	4028302
High/Low Switch	1	4028303
Humidistat	1	4028126
Humidistat Knob	1	4028127
Fuse	8	1932035
Fuse Holder	8	4028304
Control Transformer	1 1	4027307
Indicator Lamp	1 1	4028128
Relay	4	4028306
Reactivation Heater	6	4028307
Fan Motor	1	4028308
System Fan	1	4028309
Motor Pulley	1	4028144
Fan Pulley	1	4028143
Fan Belt	1	4028310
Rotor Drive Motor kit	1	4029717
Rotor Timing Drive Pulley	1	4028312
Drive Belt	1	4028313
Rotor Seal, Divider Seal	16 ft.	4026779
Desiccant Rotor	1	4028316
Process Filter	1	4020550
Caster	4	4028317
Power Cord	20 ft.	4028318

11 Wiring Diagram

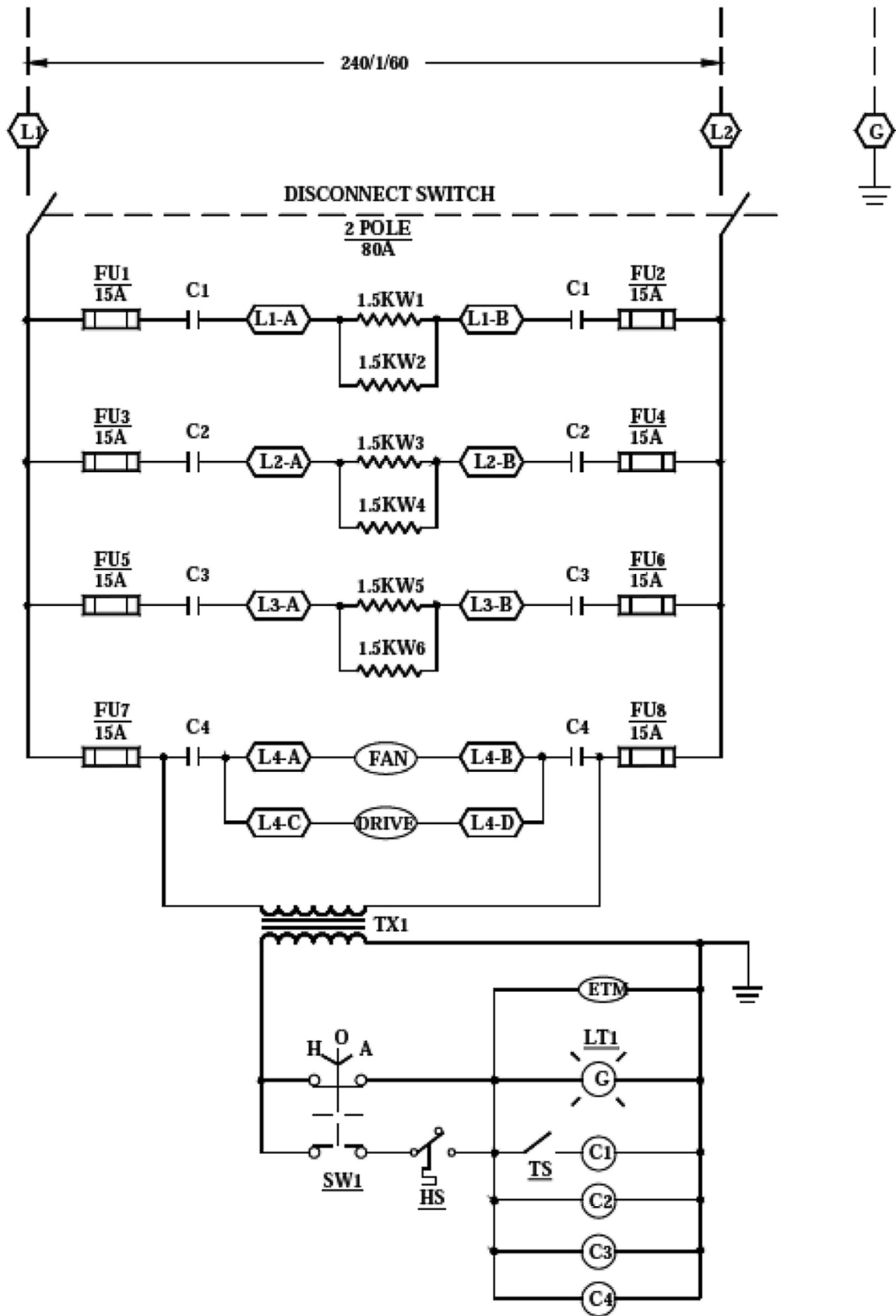

Phoenix 1200 Desiccant Limited Warranty

Warrantor:

Therma-Stor LLC
4201 Lien Rd
Madison, WI 53704
Telephone: 1-800-533-7533

Who Is Covered: This warranty extends only to the original end-user of the Phoenix 1200, and may not be assigned or transferred.

First Year Warranty: Therma-Stor Products warrants that, for one (1) year the Phoenix 1200 will operate free from any defects in materials and workmanship, or Therma-Stor Products will, at its option, repair or replace the defective part(s), free of any charge.

End-User Responsibilities: Warranty service must be performed by a Servicer authorized by Therma-Stor Products. If the end-user is unable to locate or obtain warranty service from an authorized Servicer, he should call Therma-Stor Products at the above number and ask for the Therma-Stor Products Service Department, which will then arrange for covered warranty service. Warranty service will be performed during normal working hours.

The end-user must present proof of purchase (lease) upon request, by use of the warranty card or other reasonable and reliable means. The end-user is responsible for normal care. This warranty does not cover any defect, malfunction, etc. resulting from misuse, abuse, lack of normal care, corrosion, freezing, tampering, modification, unauthorized or improper repair or installation, accident, acts of nature or any other cause beyond Therma-Stor Products' reasonable control.

Limitations and Exclusions: If any Phoenix 1200 part is repaired or replaced, the new part shall be warranted for only the remainder of the original warranty period applicable thereto (but all warranty periods will be extended by the period of time, if any, that the Phoenix 1200 is out of service while awaiting covered warranty service).

UPON THE EXPIRATION OF THE WRITTEN WARRANTY APPLICABLE TO THE PHOENIX 1200 OR ANY PART THEREOF, ALL OTHER WARRANTIES IMPLIED BY LAW, INCLUDING MERCHANTABILITY AND FITNESS FOR A PARTICULAR PURPOSE, SHALL ALSO EXPIRE. ALL WARRANTIES MADE BY THERMA-STOR PRODUCTS ARE SET FORTH HEREIN, AND NO CLAIM MAY BE MADE AGAINST THERMA-STOR PRODUCTS BASED ON ANY ORAL WARRANTY. IN NO EVENT SHALL THERMA-STOR PRODUCTS, IN CONNECTION WITH THE SALE, INSTALLATION, USE, REPAIR OR REPLACEMENT OF ANY PHOENIX 1200 OR PART THEREOF BE LIABLE UNDER ANY LEGAL THEORY FOR ANY SPECIAL, INDIRECT OR CONSEQUENTIAL DAMAGES INCLUDING WITHOUT LIMITATION WATER DAMAGE (THE END-USER SHOULD TAKE PRECAUTIONS AGAINST SAME), LOST PROFITS, DELAY, OR LOSS OF USE OR DAMAGE TO ANY REAL OR PERSONAL PROPERTY.

Some states do not allow limitations on how long an implied warranty lasts, and some do not allow the exclusion or limitation of incidental or consequential damages, so one or both of these limitations may not apply to you.

Legal Rights: This warranty gives you specific legal rights, and you may also have other rights which vary from state to state.

