

Congratulations on your purchase of the **SUPER PUMP OUT SYSTEM**. This instruction/parts manual is a guide for operating and servicing your **BLUELINE SUPER PUMP OUT SYSTEM®**.

Proper operation and service are necessary to ensure the outstanding performance of this unit. When properly maintained, your system will have a long and trouble-free life.

The following service methods outlined in this manual are detailed in a manner that operation and servicing may be performed properly and safely. Because service levels vary due to the skill of the mechanic, tools and parts availability, ensure that prior to attempting any repair, you are familiar with this equipment and have the proper tools. Any questions regarding the operation, service, or repair of this unit should be directed to your nearest **BLUELINE** dealer.

The headings **WARNING** and **CAUTION** are utilized to warn you that steps must be taken to prevent personal injury or damage to the equipment. Please make sure that you have read and understand these instructions entirely before proceeding with the operation of this unit.

Record your units identification number here for future reference or if you should need to contact the factory in the future for any reason.

This service and operations manual is written specifically for **BLUELINE SUPER PUMP OUT SYSTEM®** manufactured by:

BLUELINE EQUIPMENT LLC
2604 Liberator Drive
Prescott, AZ 86301 USA

The information contained in this document is subject to change without notice and does not represent a commitment on the part of **BLUELINE EQUIPMENT LLC**.

All rights reserved. Copyright 2008 by **BLUELINE EQUIPMENT LLC**. No part of this work may be used or reproduced in any form or means without the express written consent and permission of **BLUELINE EQUIPMENT LLC**.

Published by **BLUELINE EQUIPMENT LLC**.
First printing: October 2008
Printed in USA



SUPER PUMP OUT SYSTEM

Revision 1
October, 2008

LIMITED WARRANTY

BLUELINE warrants your Pump Out System to be free of defects in material and workmanship. This warranty shall extend to the designated parts for the specific period of time listed from the date of delivery to the user. If **BLUELINE** receives notice of any defects during the warranty period, **BLUELINE** will either, at its option, repair or replace products that prove to be defective. Any transportation, related service labor, normal maintenance and diagnostic calls are not included.

Water Pump _____ 1 year
All Other Components _____ 1 year

This warranty shall not apply to defects caused by improper operation, inadequate maintenance by the customer, unauthorized modification or misuse, improper repair, freezing or damage due to hard water scaling.

Electrical components, disposable filters, hoses, fittings, and other service maintenance items are not under warranty. Components supplied by **BLUELINE**, but provided by other manufacturers, will only be warranted to the extent that they are warranted to **BLUELINE**.

To receive warranty service, products must be returned to a **BLUELINE** designated service facility. The customer shall prepay shipping charges for products returned to **BLUELINE** for warranty evaluation and **BLUELINE** shall pay for the return of products to the customer.

BLUELINE makes no other warranty, expressed or implied, with respect to this product. **BLUELINE** disclaims the implied warranties of merchantability and fitness for a particular purpose. Any implied warranty of merchantability or fitness is limited to the specific duration of this limited warranty.

This warranty gives the customer specific legal rights, and you may also have other rights that may vary from state to state, or province to province.

The remedies provided herein are the customer's sole and exclusive remedies. In no event shall **BLUELINE** be liable for any direct, indirect, special, incidental, or consequential damages, whether based on contract, tort, or any other legal theory.

SAFETY

1. **Read the operator's manual before operating this unit.**

Failure to adhere to instructions could result in severe personal injury, property damage, or could be fatal.

2. **Operate this super pump out system only in a well-ventilated area.**

WARNING!

DO NOT operate this unit in explosive atmospheres, where there is the presence of flammable liquids, gases or dust. Pump motors create sparks which may ignite the dust or fumes.

3. This pump must be plugged into a properly installed and grounded outlet. Never remove the grounding prong or modify the plug in any way.

WARNING!

Pump must be plugged into an outlet that includes a Ground Fault Circuit Interrupter (GFCI) to reduce the risk of serious injury or death from electrical shock.

4. **DO NOT** modify this unit in any manner. Any modification could result in serious injury or fatality, and will void your warranty.

SERVICE

WARNING!

1. This motor is oil filled and sealed for cooler running. Allow 2 hours for the motor to cool before servicing. Hot oil is under pressure and could result in severe burns.

WARNING!

2. Always disconnect the power source before attempting to service or maintain the unit. The pump motor is equipped with automatic

resetting thermal protector that could restart unexpectedly.

FAILURE TO FOLLOW THIS WARNING COULD RESULT IN SERIOUS INJURY OR FATALITY.

SPECIFICATIONS

Maximum vacuum (lift in HG) 15"
Maximum flow 5400 GPH, 90 GPM
Voltage 120 @ 9.8 Amps

OPERATION

NOTE: Read and understand this section of the manual entirely before proceeding.

The S.P.S. is designed to work in conjunction with your existing truck mount or portable extraction system to enhance its performance by eliminating the need to shutdown and empty the waste tank during flood extraction.

By adjusting the flow control valve located on the top of the pump out box you can effectively manage the amount of water entering the waste tank.

Simply plug in the 120 volt power cord to a grounded power source. Connect the clear sight hose to the truck mount, connect the opposite side to the extraction hose, then attach a section of discharge hose to the side of the S.P.S. Make sure the discharge hose is level or best, a down hill run. The amount of suction achieved by the S.P.S. unit is directly affected by the height and length of suction and discharge hose. Longer hose runs or higher lift results in more head pressure, and will decrease the efficiency of the unit.

Start the extraction process and monitor the flow of water leaving the S.P.S. box thru the clear vacuum hose connected to the existing waste tank, adjust the flow control valve so that

very little or no water is visible and a steady flow is coming from the S.P.S. discharge hose.

Be sure to keep the strainer or filter basket located inside the S.P.S. tank, clean of debris to keep the unit operating at its full capacity.

! WARNING!

Always disconnect the power source before attempting to service or maintain the unit. The pump motor is equipped with automatic resetting thermal protector that could restart unexpectedly.

FAILURE TO FOLLOW THIS WARNING COULD RESULT IN SERIOUS INJURY OR FATALITY.

The S.P.S. system is controlled by an electric water sensing switch; the pump will only run when there is water in the S.P.S tank. This is to prevent running the pump dry or when first connecting the unit on site. The pump will turn on, when the water is about 1.5” from the top of the switch.

The pump will run a minimum of 4 seconds, to a maximum of 16 seconds before stopping. The pump run time will be determined by the water flow rate into the box.

Under flooding conditions, the pump will stop for 1 second every 16 seconds, and cycle automatically off and on.

DO NOT MODIFY FLOAT OR POSITION FLOAT SWITCH SO THAT THE PUMP WILL OPERATE CONTINUOUSLY. THIS WILL REDUCE PERFORMANCE

! WARNING!

NEVER dispose of waste water in a storm drain, water way or on ground areas. Always dispose of waste in accordance with Local, State and Federal laws.

8. TROUBLESHOOTING

! WARNING!

DO NOT attempt to service this unit while it is running. Always disconnect the power source before attempting to service or maintain the unit. The pump motor is equipped with automatic resetting thermal protector that could restart unexpectedly.

This motor is oil filled and sealed for cooler running. Allow 2 hours for the motor to cool before servicing. Hot oil is under pressure and could result in severe burns.

FAILURE TO FOLLOW THIS WARNING COULD RESULT IN SERIOUS INJURY OR FATALITY.

Pump Will Not Start Or Run	<ol style="list-style-type: none"> 1. Blown fuse or breaker 2. Low line voltage 3. Worn motor 4. Impeller not rotating 	<ol style="list-style-type: none"> 1. If blown, replace with proper sized fuse or reset breaker. 2. If voltage is under 108 volts, check wiring size or source. 3. Replace motor or pump. 4. If impeller will not turn, remove housing and remove blockage.
Pump Starts and Stops Too Often	<ol style="list-style-type: none"> 1. Backflow of water from hose. 	<ol style="list-style-type: none"> 1. Install or replace check valve.
Pump Will Not Shut Off or Thermal Protector Turns Off	<ol style="list-style-type: none"> 1. Dirty solid state sensor switch. 2. Defective switch. 3. Obstacle in hose. 	<ol style="list-style-type: none"> 1. Clean sensor switch face. 2. Replace sensor switch. 3. Remove pump and clean pump and hoses.
Pump Operates But Delivers Little or No Water	<ol style="list-style-type: none"> 1. Low line voltage. 2. Plugged impeller. 	<ol style="list-style-type: none"> 1. If voltage is under 108 volts, check wiring size or source. 2. Clean out impeller.
Gurgling Sound From Pump at End Of Cycle	<ol style="list-style-type: none"> 1. Air ingested into pump. 2. Time required for pumping is less than 4 seconds. 	<ol style="list-style-type: none"> 1. Wipe off surface of sensor switch. 2. Additional run time will not damage pump.

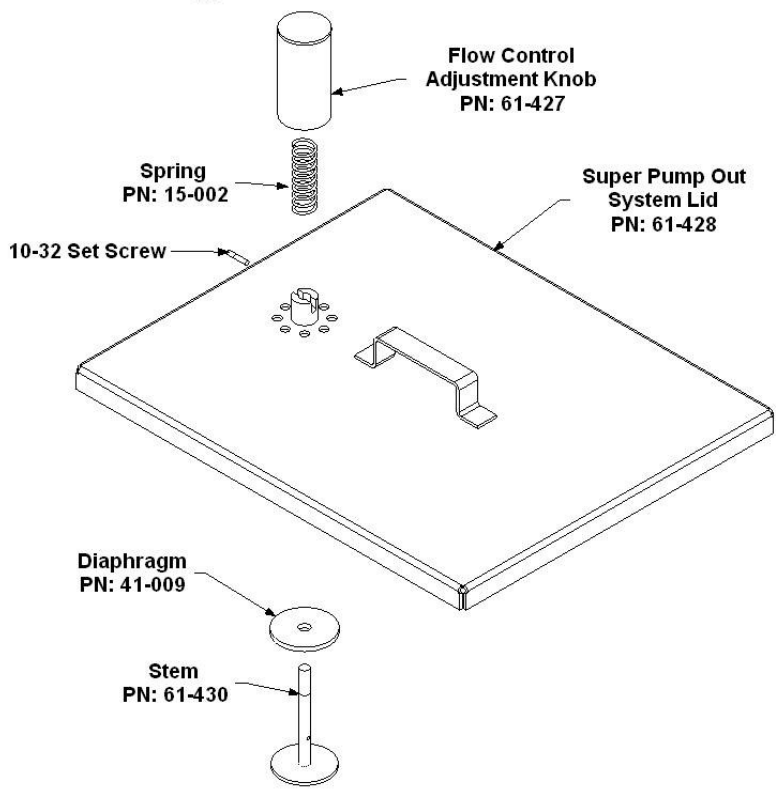
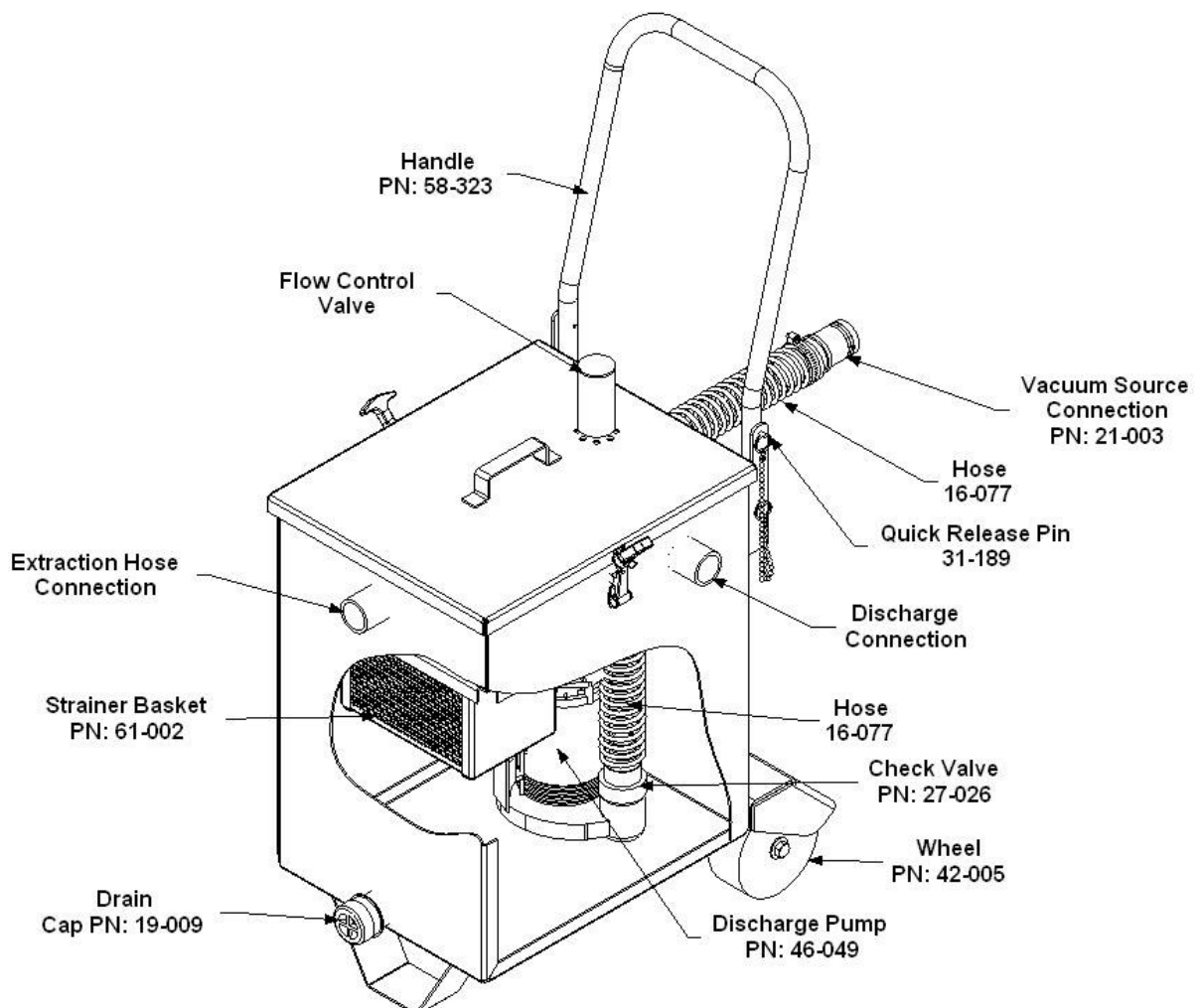

BLUELINE SUPER PUMP OUT SYSTEM

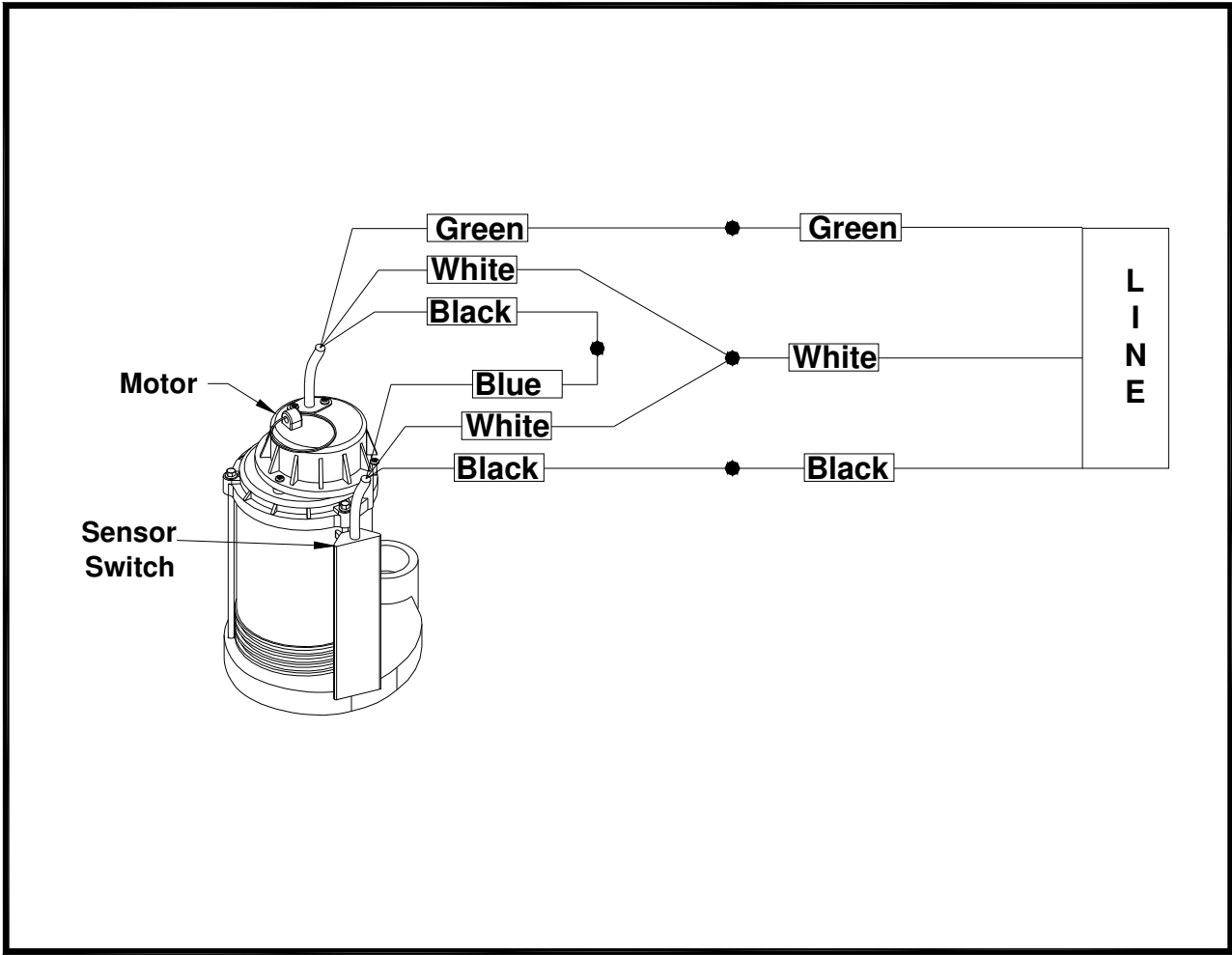

4 BLUELINE SUPER PUMP OUT SYSTEM