

MODEL 1-9 DEZ

8-17-05

FORWARD

Blastrac is pleased that you have selected this Blast Cleaning System for your surface preparation requirements. This environmentally safe, closed-cycle, surface preparation machine has been designed and built for abrasive blast cleaning of horizontal surfaces.

This manual has been prepared to assist the operator and the maintenance personnel in understanding the machine so that it may be operated in the most efficient manner and maintained in the best condition. Therefore, it is necessary that all personnel responsible for the operation and maintenance of the machine read the manual thoroughly. By following the instructions in this manual, this system can be easily and effectively operated, serviced and maintained by personnel assisted by a brief period of familiarization and training from a Blastrac technician.

Before attempting to operate, service, or maintain the machine, the personnel should thoroughly familiarize themselves with the physical makeup of the machine, be familiar with the major systems of the machine, and have an understanding of its operation.

The operating and maintenance personnel must obey all the warnings and safety precautions posted on the side of the machine and stated throughout this manual. Serious injury to personnel or severe damage to the equipment may result if the warnings and precautions are not followed, or through careless handling of this equipment.

Initial operation and maintenance must be done cautiously. Extreme care should be taken when activating any control devices until the response of the machine and its various components are clearly understood.

If you have any questions or problems in regard to the operation or capabilities of this Blastrac machine, please contact:

Blastrac
6215 Aluma Valley Drive
Oklahoma City, OK 73121
405/478-3440
800/256-3440

or your nearest Service Center.

INTRODUCTION

This manual has been prepared to assist the operator and maintenance personnel in understanding the machine so that it may be operated in the safest and most efficient manner and maintained in the best condition. Therefore, it is necessary that all personnel responsible for the operation and maintenance of the machine read and understand the manual.

Before attempting to operate service or maintain the machine, the personnel should thoroughly familiarize themselves with the physical make-up of the machine. They should be familiar with the major components of the machine and have a general understanding of overall operations.

The operating and maintenance personnel must obey all the warnings and safety precautions posted on the machine and stated throughout this manual. Serious injury to personnel or severe damage to the equipment may result if the warnings and precautions are not followed.

Warranty card must be filled out and mailed in to facilitate notification of any changes that occur after this manual is printed. We will send you manual revisions that should be inserted in the manual in accordance with instructions that will be forwarded with them.

Receipt of Machine

Examine the shipment carefully for possible damage that might have occurred while in transit. If any damage is noted, notify the transportation carrier immediately and advise Blastrac.

Table of Contents

	<u>Page Number</u>
Safety Precautions	1
1.1 Safety Instructions	2
1.2 Mechanical	3
1.3 Ventilation	5
Operator Responsibilities	6
2.1 Operator Responsibilities	7
Description and Function	8
3.1 Blast Unit – General	9
Figure 3.1.1	10
3.2 Blast Unit – Abrasive Cleaning Head	11
3.3 Blast Unit – Abrasive Control Valve	11
3.4 Blast Unit – Rebound Chamber (Plenum)	12
3.5 Blast Unit – Deflector Plate / Hopper	12
3.6 Blast Unit – Abrasive Seals	12
3.7 Blast Unit – Chassis	13
3.8 Cleaning Media (Abrasive)	13
Figure 3.1.2	14
Figure 3.1.3	15
Figure 3.1.4	16
Start-Up Procedures and Precautions	17
4.1 Start-Up Procedures	18
4.2 Blast Cleaning	19
4.3 Shut Down	20
Setting the Correct Blast Pattern	21
5.1 Setting the Correct Blast Pattern	22
Figure A	22
Figure B	23
Figure C	23
Edging Mode	24
6.1 Changing to the Edging Mode	25
Figure 6.1.1	26



Operating Instructions**1-9DEZ**

Table of Contents

Equipment Calibration	27
7.1 Equipment Calibration	28
Wear Parts	29
8.1 Wear Parts	30
8.2 Replacing Grinder Motor	31
Figure 8.1.1	32
8.2 Maintenance Log	34
Blast Wheel Replacement	35
9.1 Blast Wheel Replacement	36
Troubleshooting	38
10.1 Troubleshooting	39
10.2 Ventilation System (4-54SP Dust Collector)	41
10.3 Vacuum Adjustment	41
Specifications	38
11.1 Blast Unit	39
Recommended Spare Parts	42
12.1 Recommended Spare Parts List	43
Reference Drawings	
General Assembly	650-0011



Section 1

- 1.1 Safety Instructions
- 1.2 Safety – Mechanical
- 1.3 Safety - Ventilation



WARNING: ALL OPERATORS AND MAINTENANCE PERSONNEL SHOULD READ AND UNDERSTAND ALL OF THE *OPERATING INSTRUCTIONS* PRIOR TO OPERATING OR MAINTAINING THE 1-9DEZ.

These Blastrac® operating instructions have been specifically prepared for operating and maintenance personnel working with the Model 1-9DEZ shot-blasting system. The information in this manual is intended to provide an understanding of the 1-9DEZ to minimize safety risks and maximize 1-9DEZ performance.

1.1 Safety Instructions

All operating and maintenance personnel must observe all warnings and precautions that are listed in this manual for the Model 1-9DEZ. All safety and warning labels posted on the 1-9DEZ and the instructions included in these operating instructions must be followed.

This Blastrac® 1-9DEZ has been manufactured for specific floor preparation applications. The engineering design of this airless media blast machine incorporates several basic elements. These elements include the blast wheel, the media recycling system and the dust collection system. As a result of many years of operating and engineering experience, the features of these machines when used with the proper operating and maintenance procedures enable them to operate in an efficient and trouble-free manner.

A thorough understanding of your 1-9DEZ will help ensure that it can be operated efficiently and with minimized safety risks. No instructions, written or verbal, can be effective without the use of sound judgment and good work practices in the operation and maintenance of the 1-9DEZ. The U.S. Department of Labor Occupational Safety & Health Administration (OSHA) provides standards and regulations relating to the use of portable tools on construction sites. The operator of this 1-9DEZ should be familiar with, and understand these Regulations and Standards. These Standards and Regulations are posted on the OSHA Website at www.osha.gov.

CAUTION: ALWAYS KEEP THE ABRASIVE VALVE CONTROL LEVER IN THE OFF/CLOSED POSITION EXCEPT WHEN THE 1-9DEZ IS ACTUALLY BLAST CLEANING. IMMEDIATELY CLOSE THE ABRASIVE CONTROL VALVE BY RELEASING THE HANDLE-MOUNTED SHOT VALVE CONTROL IF YOU EXPERIENCE ANY IRREGULAR OR HAZARDOUS SITUATIONS WHILE OPERATING OR MAINTAINING THE 1-9DEZ. UNUSUAL SITUATIONS INCLUDE, BUT ARE NOT LIMITED TO, LOUD NOISE AND EXCESSIVE VIBRATION.

1.1 Cont'd

Before actual shotblasting can begin, the operator should be certain that the 1-9DEZ will clear all obstructions in the work area. Work areas must be dry and clean (no loose debris) before cleaning can begin.

WARNING: LOOSE DEBRIS MAY CAUSE A CATASTROPHIC FAILURE OF THE BLAST WHEEL RESULTING IN SERIOUS INJURY.

WARNING: KEEP ALL GUARDS IN PLACE - THE 1-9DEZ IS EQUIPPED WITH GUARDS OR COVERS FOR PARTS THAT MAY BE HAZARDOUS. IF ANY GUARDS ARE REMOVED FOR MAINTENANCE, VERIFY THAT THE GUARDS HAVE BEEN REPLACED AND ARE FUNCTIONING PRIOR TO USING THE 1-9DEZ. REFER TO DRAWINGS 650-0011 FOR CORRECT PLACEMENT OF GUARDS, COVERINGS AND OTHER 1-9DEZ COMPONENT PARTS.

All personnel in the immediate work area must wear safety glasses with side shields and hearing protection whenever the 1-9DEZ is blasting; protective clothing is also recommended. Long sleeve shirts and safety shoes should be worn. The abrasive used in the 1-9DEZ impacts the work surface at high velocity; therefore any leakage during normal operation may sting personnel in the surrounding area. The blast head must be sealed to the work surface during operation to prevent abrasive leakage. Loose clothing, long hair and jewelry should not be worn when operating or maintaining the 1-9DEZ.

1.2 Safety – Mechanical

Maintenance Mode

Maintenance mode is defined as the state or condition of the 1-9DEZ, which minimizes mechanical and electrical hazards.

The 1-9DEZ should be put into maintenance mode prior to making adjustments or attempting any maintenance. The steps for placing the 1-9DEZ in maintenance mode are listed below.

1. Move 1-9DEZ to level ground.
2. Turn off main power at electrical box located on steering handle.
3. Verify all moving parts have stopped.
4. Release grinder power trigger by simultaneously pressing the grinder power trigger and unlock button located on the back of the grinder.
5. Utilize Lock-Out/Tag-Out procedures on main power on/off switch on the electrical box located on the steering handle.



1.2 Cont'd

Most industrial and many commercial work sites will have their own Lock-Out/Tag-out procedures. The site safety personnel should be contacted to establish the procedure to be used. If the site has no formal Lockout/Tag out procedure the operator of this 1-9DEZ should be prepared to implement their own procedure including training of all operating and maintenance personnel.

All drive guards must be kept in place and in good condition except during maintenance or when repair work is being performed. Once maintenance or repair work is complete, be sure all guards are securely remounted and operating.

Safety glasses with side shields and hearing protection must always be worn when working with or near the 1-9DEZ while in use.

Loose fitting clothing should not be worn when working with the 1-9DEZ. Gloves can be worn for added protection, however loose fitting gloves could be dangerous.

The 1-9DEZ and all areas around the 1-9DEZ should be kept clean. Loose media in particular can become hazardous for foot traffic. All abrasive leaks should be stopped immediately to help keep the work area free of spilled abrasive.

Any condition(s) that may result in damage to the 1-9DEZ or cause injury to the operator and/or other personnel should be repaired immediately.

Do not attempt to make adjustments to the feed spout or any control cage components while the 1-9DEZ is in motion or the blast wheel is operating. All adjustments must be made after the 1-9DEZ as been put in Maintenance Mode (See page 3).

Obey all safety and danger signs posted on the 1-9DEZ, read and understand the *Operating Instructions* thoroughly, and follow all information posted where the 1-9DEZ is being operated.

CAUTION: ALL SAFETY AND WARNING STICKERS MUST BE KEPT IN GOOD, READABLE CONDITION. SEE DRAWING NUMBER 650-XXXX FOR STICKER DESCRIPTIONS AND LOCATIONS.

Do not operate the 1-9DEZ in the rain or when heavy moisture is present. Do not expose the abrasive supply to any type of moisture. Removal of sticky and/or rubber surfaces should be avoided when using the Blastrac[®] 1-9DEZ. Always drain unused abrasive from the 1-9DEZ and empty the dust collector hopper before transporting the 1-9DEZ.



1.3 Ventilation

The 1-9DEZ will not operate correctly without a dust collector.

The dust collector aids in the recovery of the abrasive and removes potentially hazardous dust from the air stream. If the machine is leaving shot on the ground or emitting dust, make sure your dust collector is operating correctly. Moreover, the dust collector helps maintain cleaning efficiency and minimizes the wear of the 1-9DEZ component parts.

All abrasive blast equipment must be properly ventilated to be environmentally effective. This benefits the operator, helps maintain efficiency and minimizes wear.

Keep the dust collector filters as clean as possible and dispose of the dust regularly and safely. Follow all environmental regulations when disposing of the dust. Many types of dust have chemical and physical properties that can cause fire or explosion. These hazards are minimized when the dust is removed on a regular basis as recommended.

Be sure to obtain any MSDS that may pertain to the specific use of the 1-9DEZ. Always be aware that the dust generated may require the operator to wear the appropriate breathing apparatus according to the recommendations of the MSDS.

WARNING: WEAR APPROPRIATE RESPIRATORY PROTECTION WHEN USING OR SERVICING THE MACHINE. BREATHABLE (RESPIRABLE) SILICA DUST MAY BE GENERATED BY USE OF THIS PRODUCT AND CAN CAUSE SEVERE AND PERMANENT LUNG DAMAGE, CANCER, AND OTHER SERIOUS DISEASES. DO NOT BREATHE THE DUST. DO NOT RELY ON YOUR SIGHT OR SMELL TO DETERMINE IF SILICA DUST IS IN THE AIR. SILICA DUST MAY BE IN THE AIR WITHOUT A VISIBLE DUST CLOUD. IF AIR MONITORING EQUIPMENT FOR SILICA IS NOT PROVIDED BY YOUR EMPLOYER AT YOUR WORKSITE, CONSULT YOUR EMPLOYER AND OSHA REGARDING THE APPROPRIATE RESPIRATORY PROTECTION OR PERMISSIBLE ALTERNATE PROTECTION METHODS SUCH AS AIR MONITORING AND WARNING EQUIPMENT.



Operating Instructions

1-9DEZ

Owner/Operator Responsibilities

August 2005

Section 2

2.1 Owner/Operator Responsibilities

2.1 Owner/Operator Responsibilities

1. The owner/operator is responsible for the observance of all safety precautions expressed in this manual.
2. The owner/operator should be trained by a Blastrac Technician for the operation and maintenance of Blastrac equipment.
3. The owner/operator should provide the necessary blasting media in accordance with the recommendations of a Blastrac Technician so that the 1-9DEZ will operate at its maximum efficiency.
4. The owner/operator must perform all maintenance and basic repair functions as stated and described in this manual.
5. The owner/operator should maintain an inventory of wear parts as outlined in this manual.
6. The owner/operator must dispose of all dust collector refuse according to the appropriate local, state and federal guidelines.
7. The owner/operator should provide the following minimum tools and accessories:

Hammer
Metric Wrench Set
Utility Knife
5/16" Allen Wrench
Buckets

Screwdrivers
Imperial Wrench Set
Metric Hex Key Set
Magnetic Broom
Imperial Hex Key Set



Section 3

- 3.1 Blast Unit – General
- 3.2 Blast Unit – Abrasive Cleaning Head
- 3.3 Blast Unit – Abrasive Control Valve
- 3.4 Blast Unit – Rebound Chamber (Plenum)
- 3.5 Blast Unit – Deflector Plate / Hopper
- 3.6 Blast Unit – Abrasive Seals
- 3.7 Blast Unit – Chassis
- 3.8 Cleaning Media (Abrasive)

3.1 Blast Unit – General

The Blastrac® equipment series described herein includes the 1-9DEZ Blast Unit. This model is used in conjunction with the Turbo II Dust Collector (Please refer to section 1.3 ventilation). Each combination comprises a horizontal surface preparation, closed cycle, shotblasting system. The blast unit directs high velocity, metallic abrasive toward the work surface. The impact of each individual particle causes the surface to fracture and become loose. The abrasive and the loose surface particles are then directed upward due to the force of the impact and a strong airflow created by the dust collector. The mixture of shot and contaminants enters the rebound plenum and continues its upward movement until directed into a specially designed chamber called the separator. Inside this chamber, an air wash cleans the abrasive and allows the contaminants to be extracted back to the dust collector. The clean abrasive is then gravity fed to the blast wheel and the process repeats. The blast unit is manually propelled and consists of the following elements: See figure 3.1.1 on page 9.

- Abrasive Cleaning Head
- Abrasive Control Valve
- Rebound Chamber
- Deflector Plate / Hopper
- Abrasive Seals
- Chassis
- Ventilation System
- Cleaning Media (Abrasive)

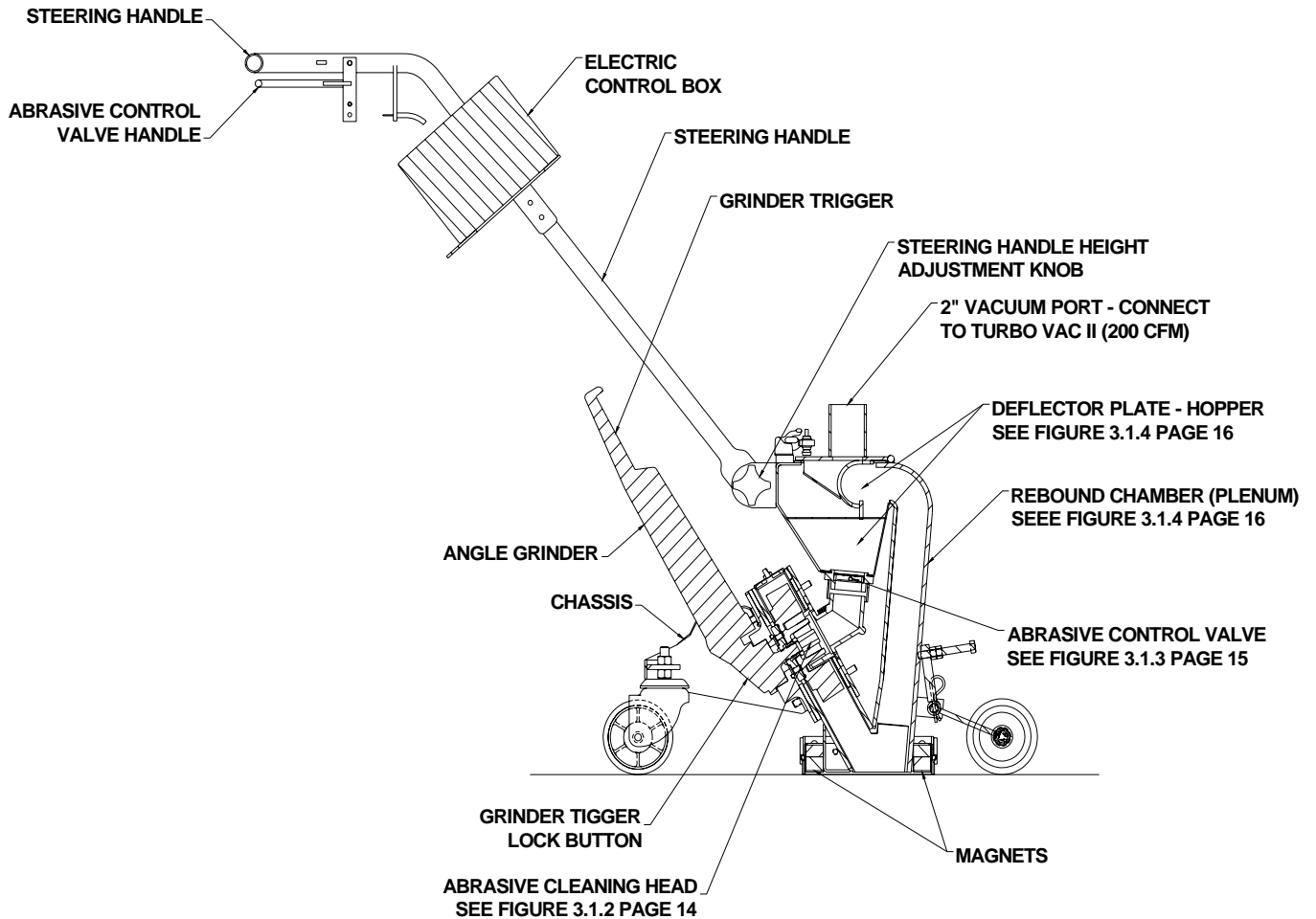

1-9DEZ General Components

(See drawing 650-0011 for a detailed parts breakdown)

FIGURE 3.1.1

3.2 Blast Unit – Abrasive Cleaning Head

This section (3.2) refers to 3.1.2 on page 14.

The center of the patented abrasive cleaning head is the four bladed, six-inch blast wheel that accelerates the abrasive towards the surface being cleaned. This center fed blast wheel propels the abrasive by centrifugal force at a speed of more than 200 mph.

This blast wheel is enclosed in an abrasion resistant housing that is also lined with abrasion resistant liners. These liners are located in areas where the most wear is present. The operator must change them periodically to protect the housing. The blast wheel is directly connected to an 8,000 RPM (no-load), 110V angle grinder.

The blast wheel is equipped with a cast in place impeller for easy maintenance. This impeller pre-accelerates the abrasive to the wheel blades in controlled portions. The impeller also acts as a timing device to ensure proper placement of abrasive on the blade face. Abrasive that is gravity fed to the center of the wheel is pre-accelerated by impeller segments and directed through the control cage. The control cage determines where the abrasive is introduced onto the rotating blades of the wheel which in turn determines where the abrasive is being “aimed”. The setting of the control cage is very important when setting up the “blast pattern.” Refer to Section 5 for setting the correct blast pattern.

3.3 Blast Unit – Abrasive Control Valve

This section (3.3) refers to Figure 3.1.3 on page 15.

The abrasive control valve regulates the amount of abrasive delivered to the blast wheel. The main component of this device is a butterfly valve surrounded by a magnetic strip. A slight gap exists between the disk on the butterfly assembly and the inner wall of the valve. When the disk is horizontal, the magnetic strip provides a seal that closes the gap with steel shot and stops the flow of abrasive. The valve is manually operated with the actuator below the handle. Should the abrasive valve need to be replaced, the lever arm should be oriented at approximately 45 degrees when the valve is closed (see figure 3.1.3) after inserting the new valve.

3.4 Blast Unit – Rebound Chamber (Plenum)

Once the abrasive has impacted the work surface, the shot is directed into the rebound plenum. This curved portion of the plenum absorbs a large percentage of the force exerted by the high velocity abrasive and helps dissipate the heat generated by the blast process.

3.5 Blast Unit – Deflector Plate / Hopper

This section (3.5) refers to 3.1.4 on page 16.

Once the contaminated abrasive leaves the rebound plenum, it enters the separator and immediately encounters the deflector plate. The deflector plate slows the abrasive down even more before it enters a tray at the bottom of the deflector plate. The contaminated abrasive hits the abrasive already at the bottom of the plate and effectively absorbs any residual force left in the moving mixture. The contaminated abrasive then falls through a curtain of high velocity clean air, which physically separates the heavy abrasive and the lighter contaminants. The air wash pulls the contaminants through the separator towards the exhaust and eventually to the dust collector. The clean abrasive falls to the bottom of the separator, then into a hopper where it can be recycled.

3.6 Blast Unit – Abrasive Seals

This section (3.6) refers to Figure 6.1.1 on page 26.

Magnetic abrasive seals are present on all sides of the rectangular opening at the bottom of the blast housing. These magnets should be charged with a load of abrasive before the blasting process begins. During the blasting process, they will attract any loose abrasive onto their surface, thus providing a “seal” to help contain the high impact abrasive from escaping the blast chamber. The leading and trailing edges of the blast chamber are equipped with additional brush seals mounted on the outside of the magnetic seals. The brush seals drag across the work surface allowing clean air to be drawn inside the 1-9DEZ. The air draw aids in the cooling and the recycling process.

3.7 Blast Unit – Chassis

All components on the blast unit are mounted on a mobile transporter. This transporter, consists of a two-wheeled rear chassis with an additional two-wheeled front caster kit for added stability.

The adjustable operator's handle connected to the chassis and may be pushed down to allow the operator to lift the blast seal over small obstructions. For safety reasons, we recommend that the bottom of the front urethane seal not be lifted more than approximately 1/8 inch from the surface being cleaned. **Warning: Lifting the seal edge beyond this may allow high velocity abrasive to escape the blast chamber (See Section 1).**

3.8 Cleaning Media (Abrasive)

Blastrac provides a variety of specially sized, high quality abrasive for Blastrac shot blasting systems. This steel abrasive is made of high quality martensitic steel to provide long operating life and minimal abrasive breakdown.

The 1-9DEZ is designed to operate with abrasive in sizes S-110 through S-330. The selection of proper abrasive is very important to the performance of the Blastrac shot cleaning system. Your Blastrac representative can help with the proper selection of abrasive for your particular application.

The steel abrasive causes minimum wear on the internal blast components. The dust and contaminants are the principal causes of component wear. A well-maintained ventilation system will minimize abrasive contamination, which helps reduce operating costs and increases the overall efficiency of the shotblasting system.

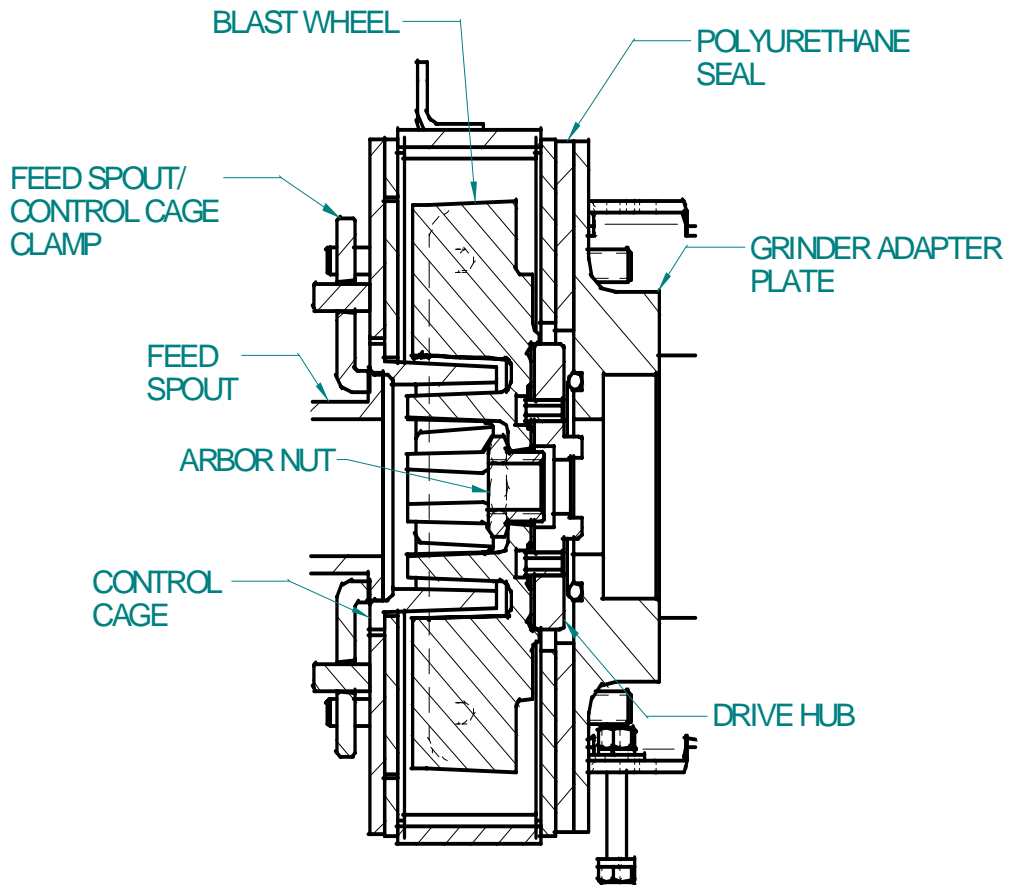

Abrasive Cleaning Head

FIGURE 3.1.2

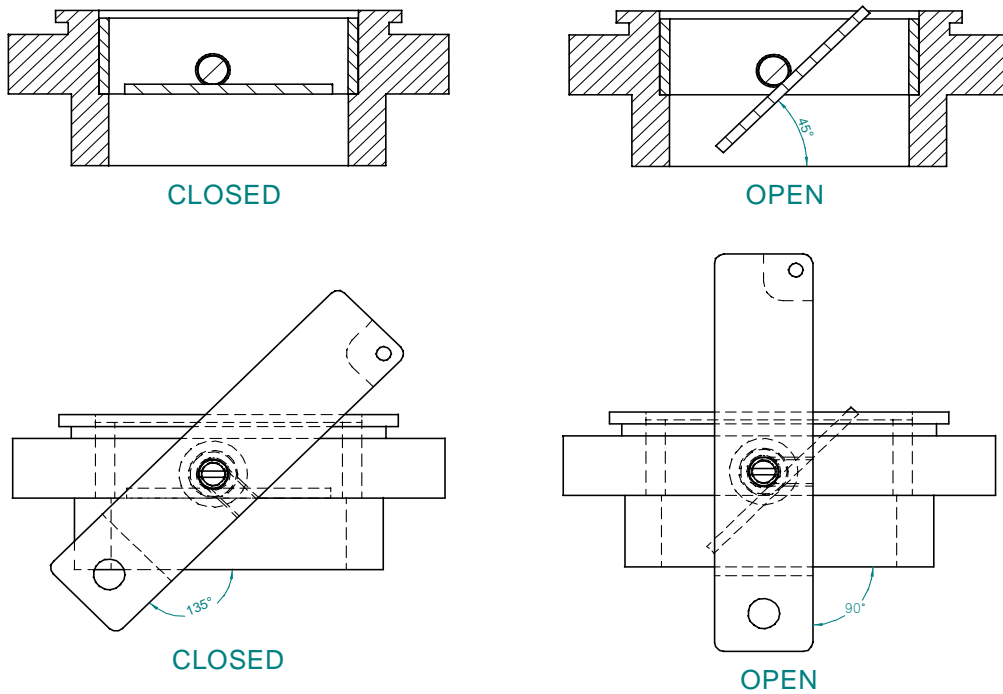
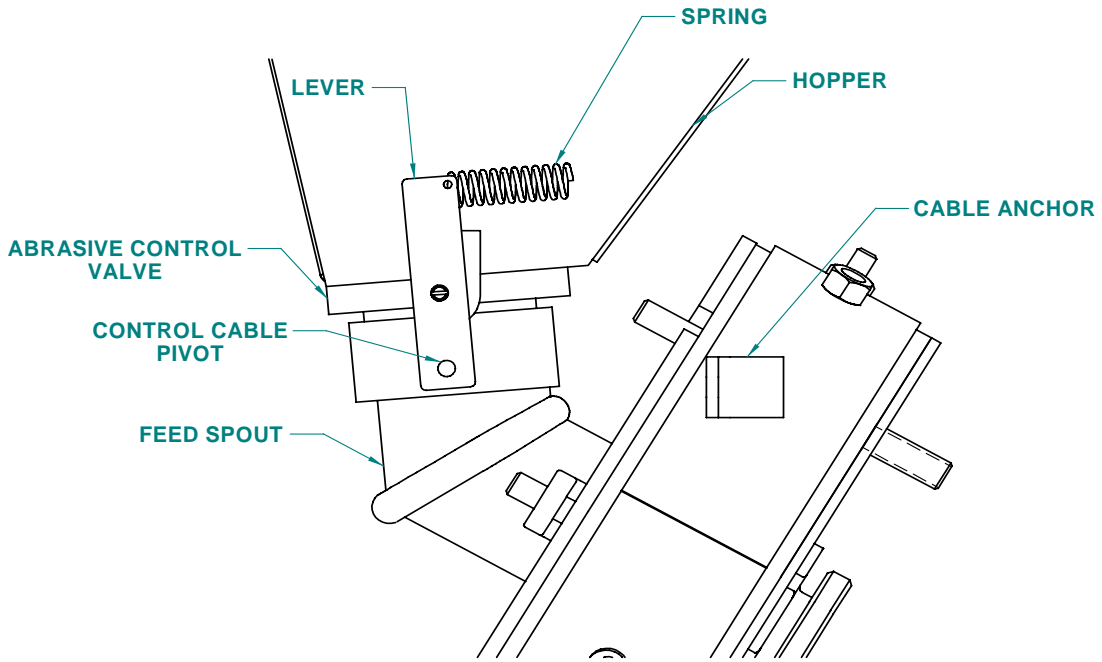

Abrasive Control Valve

FIGURE 3.1.3

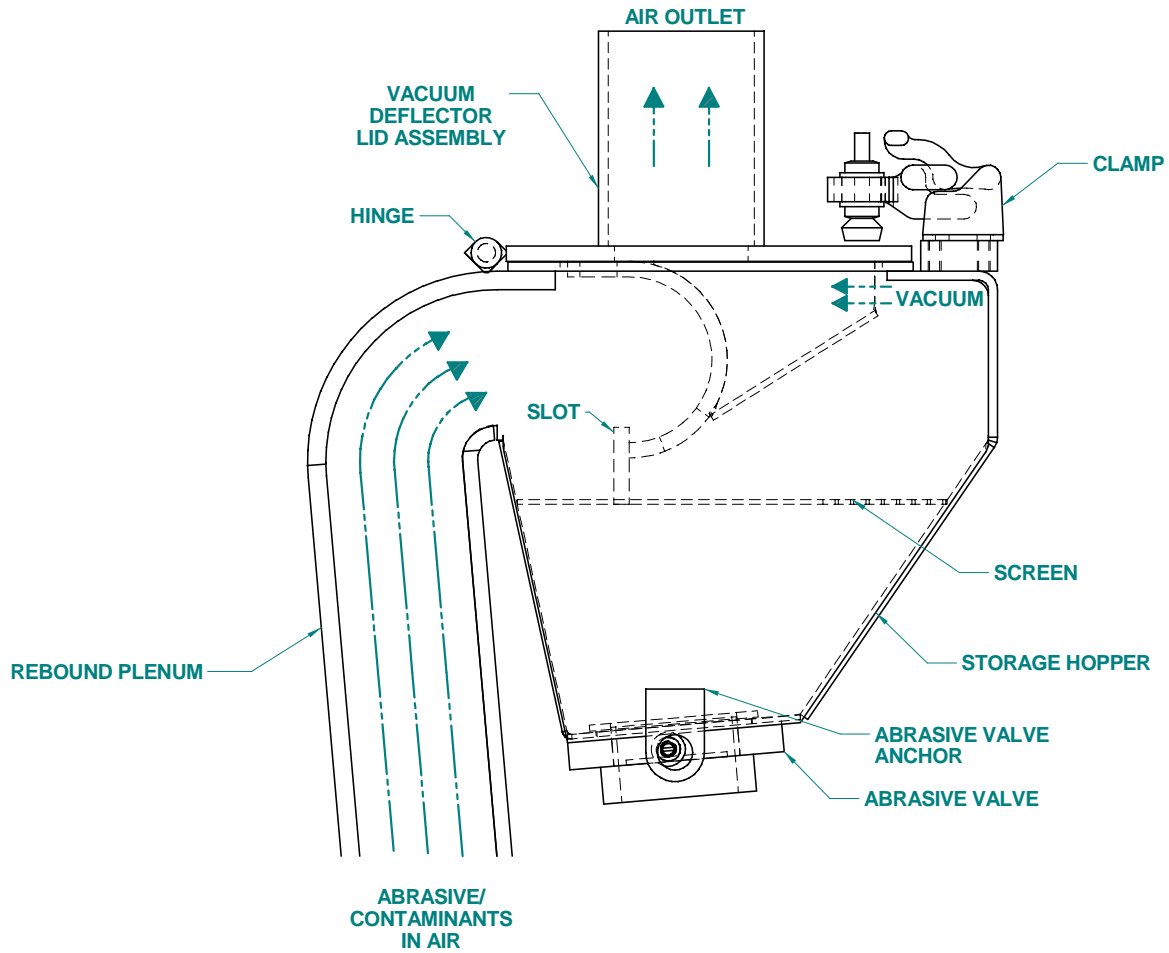

Rebound Chamber – Deflector Plate – Hopper

FIGURE 3.1.4



Operating Instructions

1-9DEZ

Start-Up, Operation, and Shut-Down Procedures

August 2005

Section 4

- 4.1 Start-Up
- 4.2 Blast Cleaning
- 4.3 Shut-Down

4.1 Start-Up

<p>WARNING: ALL OPERATING AND MAINTENANCE MUST READ AND UNDERSTAND THE <i>OPERATING INSTRUCTIONS</i> BEFORE ATTEMPTING TO OPERATE OR MAINTAIN THE 1-9DEZ. IN ADDITION, BLASTRAC HIGHLY RECOMMENDS THAT ALL OPERATING AND MAINTENANCE PERSONNEL RECEIVE TRAINING FROM AN AUTHORIZED BLASTRAC REPRESENTATIVE BEFORE ATTEMPTING TO OPERATE OR MAINTAIN THE 1-9DEZ.</p>

1. The 1-9DEZ and the dust collector should be moved to the cleaning site. Both machines can be hand-towed or moved by a lift truck.
2. **Put the 1-9DEZ in “Maintenance Mode” as described in Section 1.2.**
3. Check the dustbin of the dust collector to be sure that it is empty. At the end of each job, the dustbin should be emptied.
4. Check the blast wheel, control cage, feed spout, liners, seals and hopper parts for wear. Replace parts where necessary.
5. Check the exhaust hose for holes, deformities, potential leaks or restrictions. Repair or replace all defective items before continuing.
6. Connect the exhaust hose and clamps to the blast unit and the dust collector. Be sure the clamps are secure, creating an air tight seal.
7. All personnel in the area **MUST** wear safety glasses with side shields and hearing protection.
8. Verify that the main power switch located on the electrical box on the steering handle is in the OFF position.
9. Check the area you are about to clean. Be sure that it is dry and free of all debris that can clog or damage the 1-9DEZ.
10. Make certain that the abrasive control valve is in the closed position. Remove the separator lid and check that the shot hopper is free of debris and abrasive. Remove the screens and check the butterfly valve at the bottom of the hopper. It should be in the horizontal position. Replace the bottom screen and add approximately eight (8) to ten (10) pounds of abrasive. The level of this abrasive

4.1 Cont'd

should reach the bottom of the screen. Do not overfill; blast unit will malfunction. Replace the separator lid and secure clamps (see figure 3.1.4, page 16).

11. Check the magnetic seals on the bottom of the blast unit for metallic contaminants such as nuts, bolts, etc. remove any foreign objects. Push the blast unit forward at a normal working pace. Deposit a layer of abrasive on the floor in front of the magnets. Drive the machine over the abrasive to charge the magnets with a layer of abrasive. The abrasive will form a seal between the magnets and the floor. Remove any excess abrasive from the floor.
12. Connect grinder power cord to electrical box power.
13. Lock grinder trigger in ON position.
14. Connect electrical box power cord to site power outlet.
15. Turn on dust collector
16. Turn on main power on electrical box

4.2 Blast Cleaning

1. Start walking forward and ease the shot valve open by pulling up on the shot valve handle. **Caution: Never operate the shot valve if the machine is not moving; this could dig a hole in the concrete floor resulting in timely repairs.**
2. After cleaning a five-foot test strip, close the abrasive valve, stop the machine and check the cleaned area. The texture should be even across the 8 inch path.
3. If the brightness or texture of the test strip is uneven, refer to Section 5, "Blast Pattern", to adjust the "HOT SPOT".
4. If the cleaning is too severe or inadequate, adjust your travel speed accordingly. A faster pace will result in a lighter surface profile while a slower pace will be more aggressive and result in a deeper profile. If irregular surfaces are encountered, adjust your speed accordingly (see Section 7 - "Equipment Calibration").



4.2 Cont'd

5. The blast unit and the dust collector should be arranged so that the dust collector is centrally located. Blasting in straight lines will always give the best, most consistent results. Keep the dust hose situated between the two units so that you never have to pass across it or the power cord. Blasting during a turn will create an uneven profile. Once an area has been cleaned, the blast unit and the dust collector can be moved to an adjacent location to continue cleaning.
6. The blast unit will clear small obstructions by pushing down on the steering handle. Caution should be observed when clearing obstructions in this manner since the abrasive seal on the work surface may be broken. This may allow high velocity abrasive to escape (see section 3.7).
7. The blast pattern of the machine may change when the blast components start to wear. The operator should always note the blast pattern during normal cleaning and make adjustments or replace parts when necessary. (See Section 5 and 8.)
8. Check dust level in the dust collector at regular intervals while keeping track of the number of feet traveled. This will establish a cleaning interval for the dust collector.

4.3 Shut Down

1. Close the abrasive valve by releasing the shot valve handle.
2. Turn the main power to OFF.
3. Turn dust collector off.
4. Be sure all rotating parts are fully stopped and the 1-9DEZ is in "Maintenance Mode", as described in section 1.2, before attempting to inspect or maintain the blast unit or the dust collector.
5. At the end of each job, the dustbin and the shot hopper should be emptied. Abrasive and dust left in the 1-9DEZ or the dust collector will stick together when exposed to moisture.



Operating Instructions

1-9DEZ

Setting The Correct Blast Pattern

August 2005

Section 5

5.1 Setting the Correct Blast Pattern

5.1 Setting the Correct Blast Pattern

Setting the correct blast pattern is essential before an even, clean profile can be achieved when shotblasting with a Blastrac[®] machine. An uneven blast pattern can leave shadows on either side of the floor surface and can cause premature wear to the internal components. The importance of setting the proper blast pattern cannot be overstressed.

There are four major factors that can affect the blast pattern. They are:

1. **Wheel Rotation** - The blast wheel must be rotating in the proper direction indicated on the housing that surrounds the blast wheel. Most Blastrac[®] machines rotate in a clockwise direction when looking at the machine from the operator's position.
2. **Worn Wheel Kits** - Wheel kit components such as blades, impellers and control cages vary in different machines but perform similar functions. These kits must be periodically replaced to ensure that they produce the proper blast pattern and to eliminate excessive wear, which can cause internal component damage.
3. **Abrasive Size** - The size of the abrasive will affect the blast pattern. Different sized abrasives have different masses that will alter the "hot spot" setting. See Figure B. page 22.
4. **Control Cage Setting** -The setting of the control cage is the most critical factor in determining where the blast pattern is directed. Ideally, the blast pattern is centered so that the area being cleaned receives a consistent, even distribution of high velocity abrasive. Altering the setting of the control cage can move the blast pattern to the left or right depending on which direction the control cage is moved. Moving the control cage too far in either direction will direct the abrasive blast pattern to the side of the machine and cause premature wear to the internal components. The exact positioning of the control cage is done by trial and error.

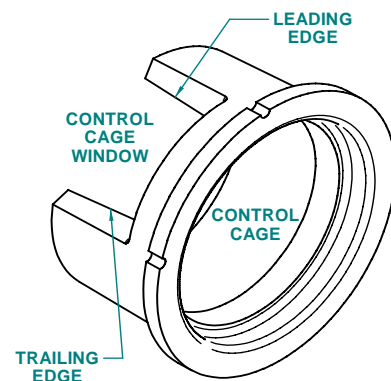

5.1 Cont'd

- The initial setting of a machine rotating in a counter-clockwise direction should be between 8:30 and 10:30 as indicated in Figures B and C. The resultant-cleaning path will determine the final setting.

These settings will vary with the abrasive size and the surface being cleaned. Once the proper control cage setting is obtained, the blast pattern should remain consistent. If the pattern begins to vary, check the blast wheel components for wear.

Control Cage "Trial & Error" Setting

The initial setting of the control cage for a machine that has the blast wheel rotating in a counter-clockwise direction is between 8:30 and 10:30. The leading edge should be at 10:30. Refer to Figures A, B and C. Place a 3/16" or 1/4" steel plate beneath the machine and blast with the abrasive control valve at full open for about 45 seconds. Do not move the machine during this test. The resulting "hot spot" should be centered as it appears on Figure B. If the "hot spot" is too far to the left, rotate the control cage in a counter-clockwise direction about 1/4" and recheck the blast pattern on the test strip. Small changes in the rotation of the control cage can move the "hot spot" significantly. If the "hot spot" is too far to the right, rotate the control cage in a clockwise direction. Once again, move the control cage in small increments until the blast pattern ("hot spot") is centered.

Note: If the blast pattern cannot be centered, check the blast wheel and be sure it is properly mounted and seated on the wheel hub located behind the blast wheel. The two pins on the hub must be seated on the back of the blast wheel before the wheel can be secured. This check must be made whenever the blast wheel is changed.

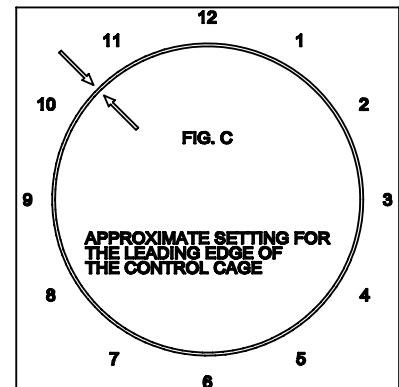
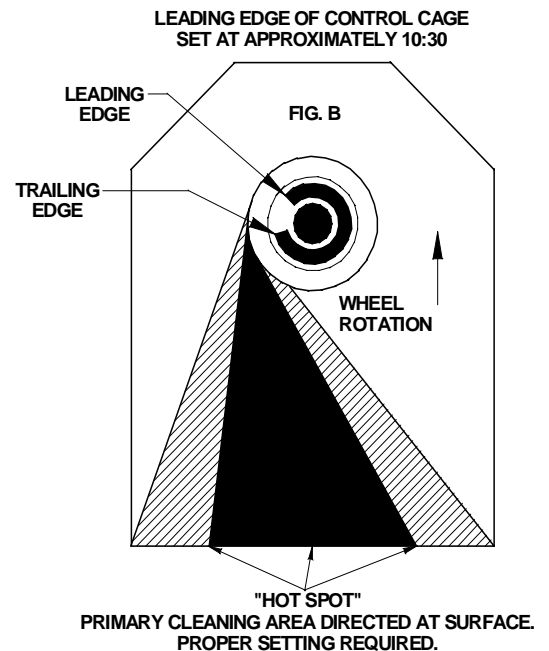

Section 6

6.1 Changing to the Edging Mode

6.1 Changing to the Edging Mode

This section (6.1) refers to Figure 6.1.1 on page 26.

The model 1-9DEZ is capable of cleaning surfaces within 1/2 inch of vertical obstructions. (This is along the side of the machine. The 1-9DEZ can be pushed as close as 1-1/2 inches from the front of the machine.) Performing the following steps sets up the edging mode:

1. Put the 1-9DEZ in “Maintenance Mode” as described in Section 1.2.
2. Remove the two hex screws holding the retainer, seal and magnet on the side of the machine where the edging is required. This requires a 3/16” hex key. Be careful to keep abrasive from entering the holes in which the screws were secured. You may want to cover these two holes with duct tape while in the edging mode to protect the threads.
3. Move the machine to the area in which the edging will be done and see if the machine can be moved freely. Adjust the height of the machine if necessary.
4. Begin cleaning in the normal fashion. Do not blast when the machine is away from the vertical surface in the edging mode since the magnetic seal is no longer present. Abrasive will disperse more readily from the side if the magnet is not in place. Keep in mind that the machine will tend to lose more abrasive while in the edging mode since the magnetic seal has been removed.

<p>WARNING: DO NOT USE THE MACHINE FOR NORMAL BLASTING WHEN IT HAS BEEN PREPARED FOR EDGING. THE MAGNET, SEAL AND RETAINER MUST BE REINSTALLED FIRST. CLOSE THE ABRASIVE VALVE BEFORE MOVING THE 1-9DEZ AWAY FROM THE VERTICAL SURFACE. FAILURE TO DO SO MAY EXPOSE NEARBY PERSONNEL TO HIGH VELOCITY ABRASIVE.</p>

RIGHT SIDE EDGE MODE

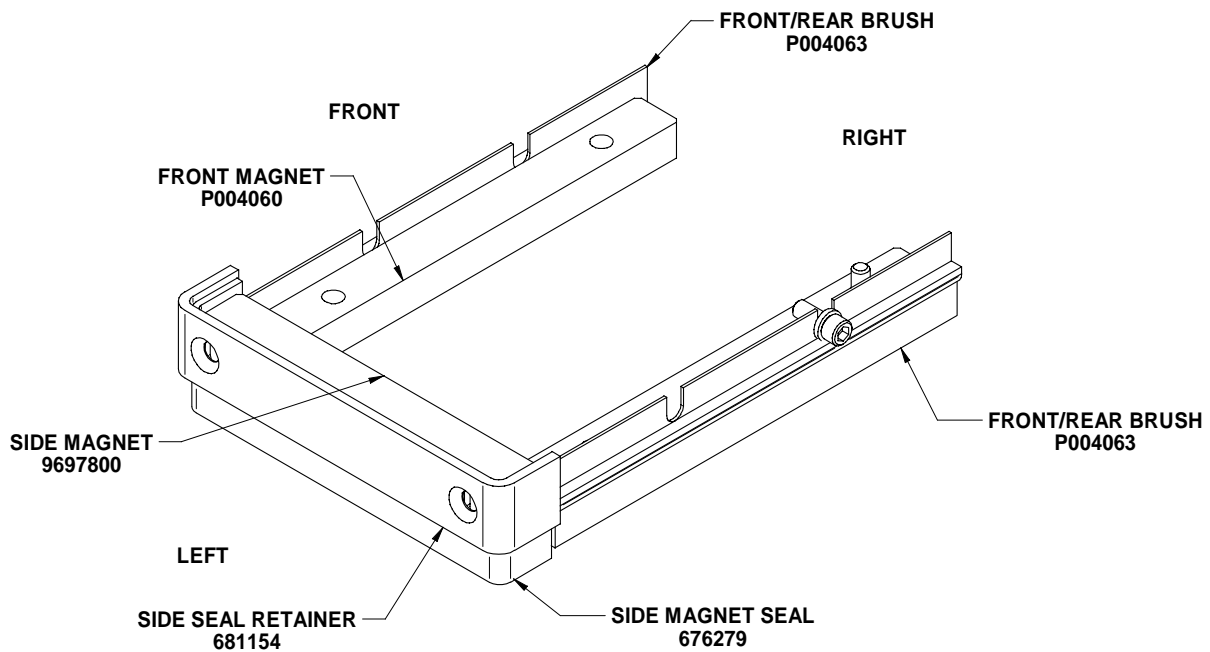

This magnet and seal illustration shows how the machine is set during the right side edging mode. This is achieved by removing the right side seal retainer, right side magnet seal and the right side magnet. For normal (non-edging) operation the right and left side arrangements are identical. For left hand edging reverse the above arrangement from right to left.

Magnetic Seal Assembly

FIGURE 6.1.1

Section 7

7.1 Equipment Calibration

7.1 Equipment Calibration

The following list of recommended set-up adjustments and reference values should be used to help obtain the optimal performance from your blast cleaning system. These should be used as starting points and can be fine-tuned after trial and observation.

WARNING: CALIBRATION OF ITEMS 1, 2 AND 6 MUST BE MADE WITH THE 1-9DEZ IN MAINTENANCE MODE (SEE SECTION 1.2).

1. **Blast Housing Height** - The bottom of the blast housing (magnets) should be between 1/8" to 1/2" above the surface being cleaned. A smaller clearance can be obtained for smooth surfaces but height may need to be adjusted for rough surfaces.
2. **Control Cage Setting** - See Section 5, "Setting the Correct Blast Pattern", figures A, B and C.
3. **Abrasive Selection Recommendations** (Steel Shot Size)
 - Brush blast of smooth concrete: S-170 to S-280 (smaller size will produce a brighter etch)
 - Rough concrete etch for coatings: S-330
4. **Exhaust Hose Length** - 25 feet of 2" I.D. exhaust hose; longer or shorter sections of hose may affect abrasive consumption or abrasive cleaning. Contact your Blastrac representative before changing the exhaust hose length.
5. **Dust Collector** – Inspect Dust Collector at 15-minute intervals to see how quickly the dustbin is being filled. Do not allow dustbin to overfill. Once fill time is determined, dump the dust at the corresponding time interval. For optimal performance use the Blastrac[®] Turbo Vac II.
6. **Handle Height** – The handle height can be adjusted to match the individual operator's height. This is accomplished by loosening the knobs and then moving the handle to the desired position. Tighten the knobs when finished.



Operating Instructions

1-9DEZ

Wear Parts

August 2005

Section 8

- 8.1 Wear Parts
- 8.2 Replacing Grinder Motor
- 8.3 Maintenance Log

8.1 Wear Parts

Certain portions of the blast unit are continuously exposed to high velocity abrasive. These areas and their corresponding parts must be periodically inspected for wear and erosion to keep from damaging components that are not normally exposed to the abrasive blast. The parts are identified on the service drawings later in this manual along with part numbers. These “wear parts” are designed to be easily replaced by the machine operator when necessary. A preventive maintenance program should be performed to monitor these areas on a regular basis. The following list outlines these areas and the time intervals involved. See figure 8.1.1 on page 30.

8.2 Replacing Grinder Motor

The grinder motor supplied with your 1-9DEZ was specially designed for this machine; do not substitute with alternate brands. Substitution may cause the assembly to fail resulting in mechanical failure and possible injury. Always follow the below specifications when replacing the grinder motor. The grinder motor supports should be assembled after the below procedure is completed.

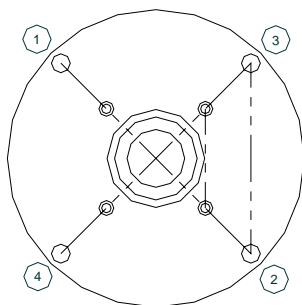
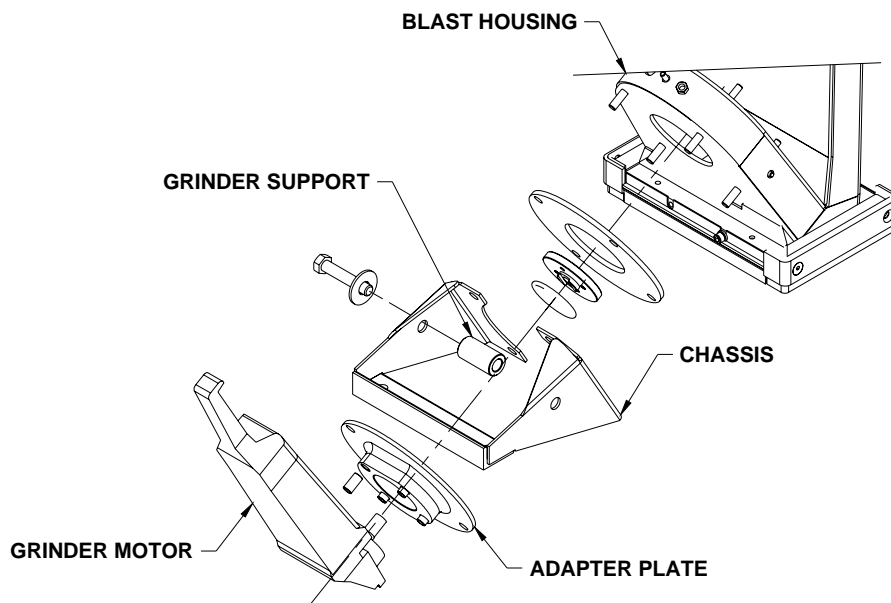

NOTE: WHEN ATTACHING THE GRINDER TO THE ADAPTER PLATE AND THE ADAPTER PLATE AND CHASSIS TO THE HOUSING, USE A CROSSING PATTERN WHEN TIGHTENING CAP SCREWS AND NUTS. SEE FIGURE AT LEFT

TORQUE SPECIFICATIONS

ARBOR NUT:	20 ft-lb
ADAPTER PLATE/CHASSIS TO HOUSING:	20 ft-lb
GRINDER TO ADAPTER PLATE:	5 ft-lb

ITEM	QUANTITY	CATALOG NUMBER	DESCRIPTION
1	1	451476	CONTROL CAGE/ 55 DEG.
2	1	459556	WHEEL/ 6-1/2" OPEN FACE
3	1	497307	LINER/TOP - SLL
4	2	681154	RETAINER/SIDE
5	2	681155	SKIRT/SIDE
6	1	P004061	LINER/L.H. SIDE - SLL
7	1	P004062	LINER/R.H. SIDE - SLL
8	2	P004063	BRUSH/FRONT-REAR
9	1	P001125	SEAL/BEARING UNIT
10	1	P004060	MAGNET/ FRONT
11	2	969780	MAGNET/SIDE
12	1	976324	BRACKET/CONTROL CAGE
13	1	P000001	VALVE/ABRASIVE CONTROL
14	1	P002617	HUB/WHEEL
15	1	P002628	MOUNTING PLATE/GRINDER
16	1	P002639	ARBOR NUT/1-8DEZ
17	1	P002656	SEAL/FELT GRINDER ADAPTER PLATE

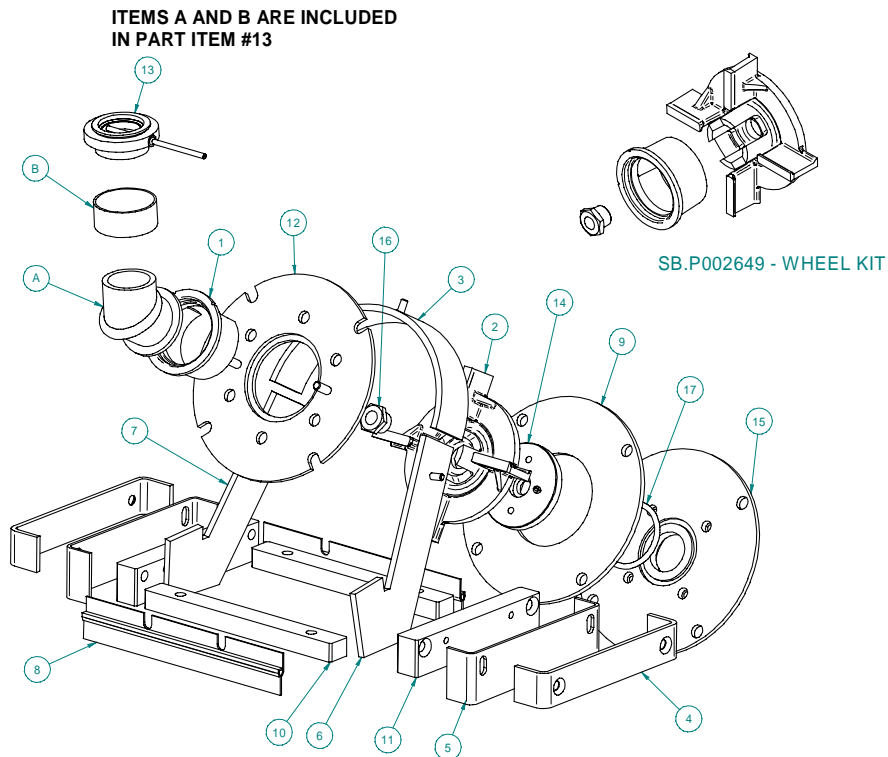

FIGURE 8.1.1

8.2 Cont'd

WARNING: THE 1-9DEZ MUST BE PLACED IN MAINTENANCE MODE (SEE SECTION 1.2) PRIOR TO CARRYING OUT ANY INSPECTION OR PART REPLACEMENT ON THE 1-9DEZ.

Part	Inspection Interval	Wear Indication	Replacement Method
Blast Wheel	5 Hrs.	Blades Worn by more than 50%	Remove arbor nut and replace (see section 9.1)
Feed Spout	50 Hrs.	Thin at Wheel Entry	Remove and replace
Control Cage	5 Hrs.	Eroded Edges	Remove and replace; adjust pattern
Rebound Chamber	50 Hrs.	Thin Sections; Wear on Welds.	Contact Blastrac [®] Service Center
Abrasive Hopper	20 Hrs.	Thin Sections; Wear at Welds; warpage	Contact Blastrac [®] Service Center
Liners	15 Hrs.	Thin Sections; Warpage; Holes	Loosen bolts, remove and replace
Blast Wheel Hub	Blast Wheel Replacement	Abrasive wear; pins missing	Remove and replace

Keep in mind that other portions of the machine require periodic inspections and maintenance. The parts mentioned above are associated with the internal abrasive blast. The power cords and exhaust hose, for example, also require close inspection and maintenance as described in other sections of this manual.

If the power cord(s) are found to have splits or cuts, they must be repaired in a manner that brings them to a same condition, function and safety, as that of a new cord(s). If this is impossible, they must be replaced.

8.3 Maintenance Log

MAINTENANCE LOG

Liners – Inspect for wear	Checked	<input type="checkbox"/>	OK	<input type="checkbox"/>	Change	<input type="checkbox"/>
Blast wheel/cage - Inspect for wear	Checked	<input type="checkbox"/>	OK	<input type="checkbox"/>	Change	<input type="checkbox"/>
Filters - Inspect - clean or replace	Checked	<input type="checkbox"/>	OK	<input type="checkbox"/>	Change	<input type="checkbox"/>
Power Cords - Inspect for splits or cuts	Checked	<input type="checkbox"/>	OK	<input type="checkbox"/>	Change	<input type="checkbox"/>
Shot valve – Inspect	Checked	<input type="checkbox"/>	OK	<input type="checkbox"/>	Change	<input type="checkbox"/>
Seals – Inspect for wear	Checked	<input type="checkbox"/>	OK	<input type="checkbox"/>	Change	<input type="checkbox"/>
Magnets & Seals – Inspect for wear	Checked	<input type="checkbox"/>	OK	<input type="checkbox"/>	Change	<input type="checkbox"/>
Feed Spout – Inspect for wear	Checked	<input type="checkbox"/>	OK	<input type="checkbox"/>	Change	<input type="checkbox"/>
Rebound Chamber – Inspect for wear	Checked	<input type="checkbox"/>	OK	<input type="checkbox"/>	Change	<input type="checkbox"/>
Abrasive Hopper – Inspect for wear	Checked	<input type="checkbox"/>	OK	<input type="checkbox"/>	Change	<input type="checkbox"/>
Blast Wheel Drive Hub – Inspect pins	Checked	<input type="checkbox"/>	OK	<input type="checkbox"/>	Change	<input type="checkbox"/>

Section 9

9.1 Blast Wheel Replacement

9.1 Blast Wheel Replacement

<p>WARNING: THE 1-9DEZ MUST BE PLACED IN THE MAINTENANCE MODE (SEE SECTION 1.2) PRIOR TO ATTEMPTING TO INSPECT, CHANGE, OR ADJUST THE BLAST WHEEL.</p>

See Section 3 and drawing 421-0001 for parts identification

1. Loosen the two control cage clamps that secure the feed spout and control cage.
2. Remove the feed spout and the control cage.
3. Outline the area around the control cage bracket with a marking pen or pencil. This will allow for easier alignment when reinstalling this part later during this procedure. Remove the four mounting nuts, flat washers and lock washers that secure the control cage mounting assembly to the blast housing. Do not loosen any other screws on the control cage mounting assembly since they are used to set the gap between the blast wheel and the control cage. Remove the control cage mounting assembly.
4. Remove the arbor nut and remove the blast wheel.
5. Check the wheel drive hub for wear and replace if necessary.
6. Install new blast wheel using the arbor nut that is included in the wheel kit. Check the two drive pins on the drive hub for wear and replace if necessary. Be sure that the new blast wheel is seated properly on the wheel hub before tightening the socket head cap screw.
7. Reinstall the control cage bracket to the blast housing using the outline made before removing the assembly.
8. Install the new control cage that was included with the wheel kit. Rotate the wheel by hand to be sure the control cage and the wheel do not make contact. The initial window setting for the control cage should be between 9:30 and 11:30.
9. Reinstall the feed spout and band seal that connects the feed spout and abrasive valve.
10. Start the grinder momentarily to check for good balance and proper clearance before shot blasting. Place back in "Maintenance Mode" and readjust if necessary.

9.1 Cont'd

11. See Section 5, "Blast Pattern", before adjusting the control cage for the correct blast pattern.

The assembly of the blast wheel and its associated parts are illustrated in Section 3, Description and Function in addition to a full parts breakdown in drawing 421-0001. Original Blastrac wheels are designed and dynamically balanced for use at high speeds. Use of any other blast wheel may cause damage to the 1-9DEZ and/or injury to operator and surrounding personnel.

Section 10

- 10.1 Blast Unit – Mechanical Troubleshooting
- 10.2 Dust Collector – Ventilation System
- 10.3 Vacuum Adjustment – Operating Tips

10.1 Mechanical Troubleshooting

WARNING: ALL OPERATORS AND MAINTENANCE PERSONNEL SHOULD READ AND UNDERSTAND ALL OF THE OPERATING INSTRUCTIONS PRIOR TO OPERATING OR MAINTAINING THE 1-9DEZ. FAILURE TO ADHERE TO THESE RECOMMENDATIONS COULD RESULT IN EQUIPMENT DAMAGE, SERIOUS INJURY OR DEATH.

Trouble	Possible Cause	Remedy
Excessive vibration - usually indicates that the blast wheel is out of balance. This condition will eventually cause bearing failure in the motor or bearing unit.	<ul style="list-style-type: none"> a. Unevenly worn wheel. b. Chipped, broken blades. c. Wheel not seated correctly on drive hub 	<ul style="list-style-type: none"> a. Replace wheel kit. Check separator and ventilation system. b. Chipped or broken blades will permanently unbalance the blast wheel and can cause damage to other components. Change wheel kit immediately. c. Reinstall blast wheel
Excessive noise - usually indicates misaligned components which causes premature wear and component failure.	<ul style="list-style-type: none"> a. Improper clearances or alignments between rotating parts, usually the control cage and the blast wheel. 	<ul style="list-style-type: none"> a. Check alignment of control cage and wheel. Allow sufficient clearance between rotating parts.
Excessive wear on blast housing rebound chamber/liners.	<ul style="list-style-type: none"> a. Improper setting of control cage. 	<ul style="list-style-type: none"> a. Abrasive is being misdirected into internal components instead of work area. Check blast pattern and readjust.
Abrasive leakage.	<ul style="list-style-type: none"> a. Improper sealing. b. Feed spout c. Improper control cage setting. d. Abrasive valve setting 	<ul style="list-style-type: none"> a. Check all seals for wear and proper height setting. b. Check feed spout alignment and rubber seal. c. Abrasive rebounding from side of machine. Check blast pattern. d. Be sure abrasive valve closes when handle is released. Readjust if necessary.

10.1 Cont'd

Trouble	Possible Cause	Remedy
Increased cleaning time.	<p>a. Low abrasive in storage hopper.</p> <p>b. Contaminated abrasive.</p> <p>c. Abrasive feed and abrasive control valve.</p> <p>d. Wheel impeller, control cage wear.</p> <p>e. Loss of consistent blast pattern, "hot spot".</p> <p>f. "Choked" wheel. (Too much abrasive delivered to blast wheel.)</p>	<p>a. Check abrasive level.</p> <p>b. Abrasive may contain substantial percentage of fines and contaminants. Check ventilation.</p> <p>c. Check for obstructions in the abrasive feed, i.e. feed spout, abrasive control valve, and separator screen.</p> <p>d. Replace wheel kit.</p> <p>e. Check blast pattern. Check the blast wheel for proper seating with the wheel hub.</p> <p>f. Close abrasive valve and gradually reopen. Check abrasive valve operation. Adjust travel limit screw on steering handle.</p>
Machine hang-up.	<p>a. Uneven work surface/ floor obstruction.</p> <p>b. Magnet setting too low.</p>	<p>a. Pull up on steering handle to raise machine to clear small obstructions or uneven work surfaces. Shut abrasive valve if obstruction cannot be cleared. Pull back machine to clear. <u>Use caution when raising seal due to high velocity abrasive exposure.</u></p> <p>b. See Section 7</p>
Decrease in cleaning surface profile.	<p>a. Machine travel speed too fast.</p> <p>b. Abrasive contaminated.</p> <p>c. Low abrasive in storage hopper.</p>	<p>a. Slow travel speed.</p> <p>b. Clean storage hopper and replace abrasive. Check ventilation system.</p> <p>c. Check abrasive level.</p>

10.2 Dust Collector – Ventilation System

Note: Once the Dust Collector has been in operation for several minutes, a stable operating level will result. Sudden changes in operation can usually be traced to a malfunction.

Trouble	Possible Cause	Remedy
Contaminated abrasive - fines and contaminants not being removed from abrasive.	<p>a. Very soft concrete removal. Excessive dust quantities entering system (will cause excessive component wear).</p> <p>b. Insufficient airflow being delivered by dust collector.</p>	<p>a. Increase machine speed to reduce the amount of concrete removal or reduce abrasive flow to wheel.</p> <p>b. Check filter: Clean or change if necessary.</p>
Visible dust discharge.	<p>a. Torn, punctured or improperly installed filter cartridges.</p> <p>b. Improper filter installation.</p>	<p>a. Check filters. Replace or reinstall immediately.</p> <p>b. Be sure there is an air tight seal around the filters.</p>

10.3 Vacuum Adjustment – Operating Tips

For normal concrete surfaces, Blastrac does not recommend using more than the 25 feet of exhaust hose supplied with the blast system. Adding additional hose can cause insufficient suction, which will allow unwanted dust and contaminants to accumulate in the abrasive, thereby causing premature wear to the blast wheel and liners. Additional hose can only be added when cleaning steel surfaces. Contact your Blastrac representative for your specific steel cleaning application.

Normal shotblasting with the blast unit will usually be accomplished with the vacuum adjustment gate partially open. Too much suction will sometimes pull the abrasive out of the separator and into the dustpan. This is particularly true when using small sizes of abrasive such as S-170 and S-230. A period of trial and error may be necessary for specific job applications. Generally speaking, the more dust generated by your shotblasting unit, the greater the suction you will need from the dust collector to keep the abrasive as clean as possible.



Operating Instructions
Specifications

1-9DEZ
August 2005

Section 11

11.1 Specifications – Blast Unit



11.1 Specifications – Blast Unit

1-9DEZ MECHANICAL DATA	
Recommended Dust Collector	Turbo Vac II (200 CFM)
Length (Base)	24 inches
Length (including handle in normal position)	45 inches
Height (excluding handle)	19.5 inches
Height (including handle in normal position)	38 inches
Width	12-3/8 inches
Weight	123 pounds
Vacuum Hose Length	25 feet
Production Capacity	Approx. 215 square feet / hour
Cleaning Path	8 inches
Power Source	110 VAC
Travel Speed	Manual



Operating Instructions

1-9DEZ

Recommended Spare Parts

August 2005

Section 12

12.1 Recommended Spare Parts List

12.1 Recommended Spare Parts List

ITEM	QUANTITY	CATALOG NUMBER	DESCRIPTION
1	1	451476	CONTROL CAGE/ 55 DEG.
2	1	459556	WHEEL/ 6-1/2" OPEN FACE
3	1	497307	LINER/TOP - SLL
4	2	681154	RETAINER/SIDE
5	2	681155	SKIRT/SIDE
6	1	P004061	LINER/L.H. SIDE - SLL
7	1	P004062	LINER/R.H. SIDE - SLL
8	2	P004063	BRUSH/FRONT-REAR
9	1	P001125	SEAL/BEARING UNIT
10	1	P004060	MAGNET/ FRONT
11	2	969780	MAGNET/SIDE
12	1	976324	BRACKET/CONTROL CAGE
13	1	P000001	VALVE/ABRASIVE CONTROL
14	1	P002617	HUB/WHEEL
15	1	P002628	MOUNTING PLATE/GRINDER
16	1	P002639	ARBOR NUT/1-8DEZ
17	1	P002656	SEAL/FELT GRINDER ADAPTER PLATE

